

**RESOLUTION NO. 23-98**

**A RESOLUTION OF THE CITY OF PANAMA CITY BEACH, FLORIDA, APPROVING THE PURCHASE FROM NGU SPORTS LIGHTING, LLC OF AN LED SPORTS LIGHTING SYSTEM FOR FRANK BROWN PARK FESTIVAL SITE, IN THE TOTAL AMOUNT OF \$1,097,250; AND AGREEING TO BE BOUND BY THE TERMS OF THAT CERTAIN AGREEMENT BETWEEN SOURCEWELL AND COOPER LIGHTING, LLC, GOVERNING THAT PURCHASE.**

**BE IT RESOLVED** that the appropriate officers of the City are authorized to execute and deliver on behalf of the City that certain proposal between the City and NGU Sports Lighting, LLC, relating to a new LED Sports Lighting System for the Frank Brown Park Festival Site, in the total amount of One Million, Ninety-Seven Thousand, Two Hundred Fifty Dollars and No Cents (\$1,097,250.00), in substantially the form **attached** as Exhibit A and presented to the Council today, with such changes, insertions or omissions as may be approved by the City Manager.

**AND BE IT FURTHER RESOLVED** that by accepting the proposal referenced above, that the City agreed to be bound to the same terms and conditions as were obtained by Sourcewell, through an advertised, competitive bidding process, Contract No. 071619, in the form **attached** as Exhibit B.

**THIS RESOLUTION** shall be effective immediately upon passage.

**PASSED** in regular session this 26<sup>th</sup> day of January, 2023.

**CITY OF PANAMA CITY BEACH**

By: \_\_\_\_\_

  
Mark Sheldon, Mayor

**ATTEST:**

  
\_\_\_\_\_  
Lynne Fasone, City Clerk



**Solicitation Number: #071619**

**CONTRACT**

This Contract is between Sourcewell, 202 12th Street Northeast, P.O. Box 219, Staples, MN 56479 (Sourcewell) and **Cooper Lighting LLC**, 125 East Jefferson Street, Syracuse, NY 13202 (Vendor).

Sourcewell is a State of Minnesota local government agency and service cooperative created under the laws of the State of Minnesota (Minnesota Statutes Section 123A.21) that offers cooperative procurement solutions to its members. Participation is open to all levels of governmental entity, higher education, K-12 education, nonprofit, tribal government, and other public entities located in the United States and Canada.

Vendor desires to contract with Sourcewell to provide equipment, products, or services to Sourcewell and its Members (Members).

**1. TERM OF CONTRACT**

A. **EFFECTIVE DATE.** This Contract is effective upon the date of the final signature below.

B. **EXPIRATION DATE AND EXTENSION.** This Contract expires August 27, 2023, unless it is cancelled sooner pursuant to Article 24. This Contract may be extended up to one additional one-year period upon request of Sourcewell and with written agreement by Vendor.

C. **SURVIVAL OF TERMS.** Articles 11 through 16 survive the expiration or cancellation of this Contract.

**2. EQUIPMENT, PRODUCTS, OR SERVICES**

A. **EQUIPMENT, PRODUCTS, OR SERVICES.** Vendor will provide the Equipment, Products, or Services as stated in its Proposal submitted under the Solicitation Number listed above. Vendor's Equipment, Products, or Services Proposal (Proposal) is attached and incorporated into this Contract.

All Equipment and Products provided under this Contract must be new/current model. Vendor may offer close-out or refurbished Equipment or Products if they are clearly indicated in Vendor's product and pricing list. Unless agreed to by the Member in advance, Equipment or Products must be delivered as operational to the Member's site.

This Contract offers an indefinite quantity of sales, and while substantial volume is anticipated, sales and sales volume are not guaranteed.

**B. LAWS AND REGULATIONS.** All Equipment, Products, or Services must comply fully with applicable federal laws and regulations, and with the laws of the state or province in which the Equipment, Products, or Services are sold.

**C. WARRANTY.** Vendor warrants that all Equipment, Products, and Services furnished are free from liens and encumbrances, and are free from defects in design, materials, and workmanship. In addition, Vendor warrants the Equipment, Products, and Services are suitable for and will perform in accordance with the ordinary use for which they are intended. Vendor's dealers and distributors must agree to assist the Member in reaching a resolution in any dispute over warranty terms with the manufacturer. Any manufacturer's warranty that is effective past the expiration of the Vendor's warranty will be passed on to the Member.

**D. WHAT THE WARRANTY COVERS:** Vendor warrants to the end user of the original installation location ("Sourcewell" or "Member") that new Vendor fixtures purchased from Vendor or an authorized distributor ("Products") shall, for a period of ten (10) years from the date of original shipment (the "Warranty Period"), be free from defects in material and workmanship of the Vendor fixtures. During the Warranty Period, Vendor's sole obligation, and Sourcewell's or Member's sole remedy, shall be, at Vendor's sole discretion, to repair, replace, or provide a refund for Products found to be defective as defined herein. Vendor shall not be responsible for any other costs, including for the costs of: labor relating to de-installation of any defective Product or re-installation of any replacement Product; the shipment of defective or replacement Product; or post-installation testing of any Product for purposes of this Warranty. Vendor shall not be bound by any terms, conditions, or representations, which are not stated herein including, but not limited to, any statements made by distributors or re-sellers.

**E. WHAT VOIDS OR IS NOT COVERED UNDER THE WARRANTY:** This Warranty is void, and Vendor shall have no liability hereunder, with respect to a Product if Sourcewell or Member or any person other than an employee, independent contractor, or subcontractor of Vendor: 1. install(s) or use a Product in a manner that is not in accordance with the applicable specifications and instructions, including, but not limited to, over/under voltage or current conditions, excessive switching cycles, operating hours, or outside any applicable operating conditions; 2. without the prior written consent of Vendor, modify, tamper, or disassemble a Product, including, without limitation, alter serial numbers or removes factory supplied stickers or labels of a Product; or 3. use unauthorized components, parts, accessories, or other materials to repair a Product. This Warranty does not cover: (a) cosmetic defects; (b) damage, defects, or failure caused by: (i.) acts of God; (ii.) accident, misuse, misapplication, abuse, negligence, or modification of any part of the Product; (iii.) improper storage, installation, repair, operation, inspection or maintenance; (iv.) the use of unauthorized

components, parts, accessories, or other materials or by equipment or products manufactured by someone other than Vendor; v. wrong or inadequate electrical current or connection; or vi. transit. (c) Other equipment or products manufactured by someone other than Vendor. (d) Labor or contractor costs associated with removing or replacing Vendor lighting fixtures.

F. WARRANTY ACTIVATION/SERVICE CLAIMS: Sourcewell or Member must make a valid Warranty claim to Vendor in order to receive coverage under the Warranty. Warranty claims can be serviced by contacting Vendor's customer service and sales center: Phone: (315) 579-2873; Email: ephesuswarranty@eaton.com. If Sourcewell or Member is unsure whether a situation exists that is covered by the Warranty, then Sourcewell or Member may contact Vendor's customer service and sales center at the phone number or email address listed for assistance.

G. REPLACEMENT OF OR REPAIR OF PRODUCT: Vendor, in its discretion, may use comparable product of equal or greater value to replace a Product that meets the conditions of this Warranty. Furthermore, in performing repairs to a Product that meets the conditions of this Warranty, Vendor reserves the right to utilize new, reconditioned, refurbished, repaired or remanufactured products or parts. Repaired or replaced Products are warranted for the remainder of the original Warranty Period. Vendor reserves the right to examine all returned Products, their specific installation location, and patterns of usage to determine the cause of failure.

H. LIMITATION OF WARRANTY: THE FOREGOING WARRANTIES ARE EXCLUSIVE EXCEPT FOR WARRANTY OF TITLE. VENDOR DISCLAIMS ALL OTHER WARRANTIES, EXPRESS OR IMPLIED, INCLUDING ANY IMPLIED WARRANTY OF FITNESS FOR A PARTICULAR PURPOSE. CORRECTION OF NON-CONFORMITIES IN THE MANNER AND FOR THE PERIOD OF TIME PROVIDED ABOVE SHALL CONSTITUTE VENDOR'S SOLE LIABILITY AND SOURCEWELL'S AND MEMBER'S EXCLUSIVE REMEDY FOR FAILURE OF VENDOR TO MEET ITS WARRANTY OBLIGATIONS, WHETHER CLAIMS ARE BASED IN CONTRACT (INCLUDING WARRANTY), IN TORT (INCLUDING NEGLIGENCE OR STRICT LIABILITY) OR OTHERWISE.

I. DEALERS AND DISTRIBUTORS. Upon Contract execution, Vendor will make available to Sourcewell a means to validate or authenticate Vendor's authorized Distributors/Dealers relative to the Equipment, Products, and Services related to this Contract. This list may be updated from time-to-time and is incorporated into this Contract by reference. It is the Vendor's responsibility to ensure Sourcewell receives the most current version of this list.

### 3. PRICING

All Equipment, Products, or Services under this Contract will be priced as stated in Vendor's Proposal.

Regardless of the payment method chosen by the Member, the total cost associated with any purchase option of the Equipment, Products, or Services must always be disclosed in the pricing quote to the applicable Member at the time of purchase.

When providing pricing quotes to Members, all pricing quoted must reflect a Member's total cost of acquisition. This means that the quoted cost is for delivered Equipment, Products, and Services that are operational for their intended purpose, and includes all costs to the Member's requested delivery location.

A. SHIPPING AND SHIPPING COSTS. All delivered Equipment and Products must be properly packaged. Damaged Equipment and Products may be rejected. If the Equipment or Product is

damaged, and the damage is not readily apparent at the time of delivery, Vendor must permit the Equipment and Products to be returned for service through a warranty claim within a reasonable time at no cost to Sourcewell or its Members. Members reserve the right to inspect the Equipment and Products at a reasonable time after delivery where circumstances or conditions prevent effective inspection of the Equipment and Products at the time of delivery. Vendor must arrange for and pay for the return shipment on Equipment and Products that arrive in a defective or inoperable condition.

Sourcewell may declare the Vendor in breach of this Contract if the Vendor intentionally delivers substandard or inferior Equipment or Products. In the event of the delivery of nonconforming Equipment and Products, the Member will notify the Vendor as soon as possible and the Vendor will replace nonconforming Equipment and Products with conforming Equipment and Products that are acceptable to the Member.

B. SALES TAX. Each Member is responsible for supplying the Vendor with valid tax-exemption certification(s). When ordering, Members must indicate if it is a tax-exempt entity.

C. PAYMENT TERMS. All payments are due net thirty (30) days in full from date of invoice, unless a longer term is required by statute or otherwise agreed to by Vendor and Member.

D. HOT LIST PRICING. At any time during this Contract, Vendor may offer a specific selection of Equipment, Products, or Services at discounts greater than those listed in the Contract. When Vendor determines it will offer Hot List Pricing, it must be submitted electronically to Sourcewell in a line-item format. Equipment, Products, or Services may be added or removed from the Hot List at any time through a Sourcewell Price and Product Change Form as defined in Article 4 below.

Hot List program and pricing may also be used to discount and liquidate close-out and discontinued Equipment and Products as long as those close-out and discontinued items are clearly identified as such. Current ordering process and administrative fees apply. Hot List Pricing must be published and made available to all Members.

#### **4. PRODUCT AND PRICING CHANGE REQUESTS**

Vendor may request Equipment, Product, or Service changes, additions, or deletions at any time. All requests must be made in writing by submitting a signed Sourcewell Price and Product Change Request Form to the assigned Sourcewell Contract Administrator. This form is available from the assigned Sourcewell Contract Administrator. At a minimum, the request must:

- Identify the applicable Sourcewell contract number
- Clearly specify the requested change
- Provide sufficient detail to justify the requested change
- Individually list all Equipment, Products, or Services affected by the requested change, along with the requested change (e.g., addition, deletion, price change)
- Include a complete restatement of pricing documentation in Microsoft Excel with the

4

effective date of the modified pricing, or product addition or deletion. The new pricing restatement must include all Equipment, Products, and Services offered, even for those items where pricing remains unchanged.

A fully executed Sourcewell Price and Product Request Form will be become an amendment to this Contract and be incorporated by reference.

## **5. MEMBERSHIP, CONTRACT ACCESS, AND MEMBER REQUIREMENTS**

A. **MEMBERSHIP.** Membership in Sourcewell is open to public and nonprofit entities across the United States and Canada; such as municipal, state/province, K-12 and higher education, tribal government, and other public entities.

The benefits of this Contract should be available to all Members that can legally access the Equipment, Products, or Services under this Contract. A Member's authority to access this Contract is determined through its cooperative purchasing, interlocal, or joint powers laws. Any entity accessing benefits of this Contract will be considered a Service Member of Sourcewell during such time of access. Vendor understands that a Member's use of this Contract is at the Member's sole convenience and Members reserve the right to obtain like Equipment, Products, or Services from any other source.

Vendor is responsible for familiarizing its sales and service forces with Sourcewell membership requirements and documentation and will encourage potential members to join Sourcewell. Sourcewell reserves the right to add and remove Members to its roster during the term of this Contract.

B. **PUBLIC FACILITIES.** Vendor's employees may be required to perform work at government-owned facilities, including schools. Vendor's employees and agents must conduct themselves in a professional manner while on the premises, and in accordance with Member policies and procedures, and all applicable laws.

## **6. MEMBER ORDERING AND PURCHASE ORDERS**

A. **PURCHASE ORDERS AND PAYMENT.** To access the contracted Equipment, Products, or Services under this Contract, Member must clearly indicate to Vendor that it intends to access this Contract; however, order flow and procedure will be developed jointly between Sourcewell and Vendor. Typically a Member will issue a purchase order directly to Vendor. Members may use their own forms for purchase orders, but it should clearly note the applicable Sourcewell contract number. Members will be solely responsible for payment and Sourcewell will have no liability for any unpaid invoice of any Member.

B. **ADDITIONAL TERMS AND CONDITIONS.** Additional terms and conditions to a purchase order may be negotiated between a Member and Vendor, such as job or industry-specific requirements, legal requirements (such as affirmative action or immigration status requirements), or specific local policy requirements. Any negotiated additional terms and

conditions must never be less favorable to the Member than what is contained in Vendor's Proposal.

C. **PERFORMANCE BOND.** If requested by a Member, Vendor will provide a performance bond that meets the requirements set forth in the Member's purchase order.

D. **SPECIALIZED SERVICE REQUIREMENTS.** In the event that the Member requires service or specialized performance requirements (such as e-commerce specifications, specialized delivery requirements, or other specifications and requirements) not addressed in this Contract, the Member and the Vendor may enter into a separate, standalone agreement, apart from this Contract. Sourcewell, including its agents and employees, will not be made a party to a claim for breach of such agreement.

E. **TERMINATION OF PURCHASE ORDERS.** Members may terminate a purchase order, in whole or in part, immediately upon notice to Vendor in the event of any of the following events:

1. The Member fails to receive funding or appropriation from its governing body at levels sufficient to pay for the goods to be purchased;
2. Federal or state laws or regulations prohibit the purchase or change the Member's requirements; or
3. Vendor commits any material breach of this Contract or the additional terms agreed to between the Vendor and a Member.

F. **GOVERNING LAW AND VENUE.** The governing law and venue for any action related to a Member's purchase order will be determined by the Member making the purchase.

## **7. CUSTOMER SERVICE**

A. **PRIMARY ACCOUNT REPRESENTATIVE.** Vendor will assign an Account Representative to Sourcewell for this Contract and must provide prompt notice to Sourcewell if that person is changed. The Account Representative will be responsible for:

- Maintenance and management of this Contract;
- Timely response to all Sourcewell and Member inquiries; and
- Business reviews to Sourcewell and Members, if applicable.

B. **BUSINESS REVIEWS.** Vendor must perform a minimum of one business review with Sourcewell per contract year. The business review will cover sales to members, pricing and contract terms, administrative fees, supply issues, customer issues, and any other necessary information.

## **8. REPORT ON CONTRACT SALES ACTIVITY AND ADMINISTRATIVE FEE PAYMENT**

A. **CONTRACT SALES ACTIVITY REPORT.** Each calendar quarter, Vendor must provide a contract

sales activity report (Report) to the Sourcewell Contract Administrator assigned to this Contract. A Report must be provided regardless of the number or amount of sales during that quarter (i.e., if there are no sales, Vendor must submit a report indicating no sales were made).

The Report must contain the following fields:

- Customer Name (e.g., City of Staples Highway Department);
- Customer Physical Street Address;
- Customer City;
- Customer State;
- Customer Zip Code;
- Customer Contact Name;
- Customer Contact Email Address;
- Customer Contact Telephone Number;
- Sourcewell Assigned Entity/Member Number;
- Item Purchased Description;
- Item Purchased Price;
- Sourcewell Administrative Fee Applied; and
- Date Purchase was invoiced/sale was recognized as revenue by Vendor.

B. ADMINISTRATIVE FEE. In consideration for the support and services provided by Sourcewell, the Vendor will pay an administrative fee to Sourcewell on all Equipment, Products, and Services provided to Members. The Vendor will submit a check payable to Sourcewell for the percentage of administrative fee stated in the Proposal multiplied by the total sales of all Equipment, Products, and Services purchased by Members under this Contract during each calendar quarter. Payments should note the Sourcewell-assigned contract number in the memo and must be mailed to the address above "Attn: Accounts Receivable." Payments must be received no later than forty-five (45) calendar days after the end of each calendar quarter.

Vendor agrees to cooperate with Sourcewell in auditing transactions under this Contract to ensure that the administrative fee is paid on all items purchased under this Contract.

In the event the Vendor is delinquent in any undisputed administrative fees, Sourcewell reserves the right to cancel this Contract and reject any proposal submitted by the Vendor in any subsequent solicitation. In the event this Contract is cancelled by either party prior to the Contract's expiration date, the administrative fee payment will be due no more than thirty (30) days from the cancellation date.

## **9. AUTHORIZED REPRESENTATIVE**

Sourcewell's Authorized Representative is its Chief Procurement Officer.

Vendor's Authorized Representative is the person named in the Vendor's Proposal. If Vendor's Authorized Representative changes at any time during this Contract, Vendor must promptly notify Sourcewell in writing.



## **10. ASSIGNMENT, AMENDMENTS, WAIVER, AND CONTRACT COMPLETE**

A. **ASSIGNMENT.** Neither the Vendor nor Sourcewell may assign or transfer any rights or obligations under this Contract without the prior consent of the parties and a fully executed assignment agreement. Such consent will not be unreasonably withheld.

B. **AMENDMENTS.** Any amendment to this Contract must be in writing and will not be effective until it has been fully executed by the parties.

C. **WAIVER.** If either party fails to enforce any provision of this Contract, that failure does not waive the provision or the right to enforce it.

D. **CONTRACT COMPLETE.** This Contract contains all negotiations and agreements between Sourcewell and Vendor. No other understanding regarding this Contract, whether written or oral, may be used to bind either party.

E. **RELATIONSHIP OF THE PARTIES.** The relationship of the parties is one of independent contractors, each free to exercise judgment and discretion with regard to the conduct of their respective businesses. This Contract does not create a partnership, joint venture, master-servant, principal-agent, or any other relationship.

## **11. LIABILITY**

Vendor agrees to indemnify, defend and hold harmless Sourcewell and its agents and employees from all third-party claims or causes of action, including reasonable attorney's fees, asserted against Sourcewell and directly and proximately caused by the negligent acts or omissions or misconduct of Vendor, its agents or its employees or its obligations hereunder. In no event will either party be liable for any indirect, punitive, special, incidental or consequential damage in connection with or arising out of this Contract however it arises, whether in contract, tort, strict product liability or otherwise.

## **12. AUDITS**

Sourcewell reserves the right to review the books, records, documents, and accounting procedures and practices of the Vendor relevant to this Contract for a minimum of six (6) years from the end of this Contract. This clause extends to Members as it relates to business conducted by that Member under this Contract.

## **13. GOVERNMENT DATA PRACTICES**

Vendor and Sourcewell must comply with the Minnesota Government Data Practices Act, Minnesota Statutes Chapter 13, as it applies to all data provided by or provided to Sourcewell under this Contract and as it applies to all data created, collected, received, stored, used, maintained, or disseminated by the Vendor under this Contract.

If the Vendor receives a request to release the data referred to in this article, the Vendor must immediately notify Sourcewell and Sourcewell will assist with how the Vendor should respond to the request.

#### **14. INTELLECTUAL PROPERTY**

As applicable, Vendor agrees to indemnify and hold harmless Sourcewell and its Members against any and all suits, claims, judgments, and costs instituted or recovered against Sourcewell or Members by any person on account of the use of any Equipment or Products by Sourcewell or its Members supplied by Vendor in violation of applicable patent or copyright laws.

#### **15. PUBLICITY, MARKETING, AND ENDORSEMENT**

A. **PUBLICITY.** Any publicity regarding the subject matter of this Contract must not be released without prior written approval from the Authorized Representatives. Publicity includes notices, informational pamphlets, press releases, research, reports, signs, and similar public notices prepared by or for the Vendor individually or jointly with others, or any subcontractors, with respect to the program, publications, or services provided resulting from this Contract.

B. **MARKETING.** Any direct advertising, marketing, or offers with Members must be approved by Sourcewell. Materials should be sent to the Sourcewell Contract Administrator assigned to this Contract.

C. **ENDORSEMENT.** The Vendor must not claim that Sourcewell endorses its Equipment, Products, or Services.

#### **16. GOVERNING LAW, JURISDICTION, AND VENUE**

Minnesota law governs this Contract. Venue for all legal proceedings out of this Contract, or its breach, must be in the appropriate state court in Todd County or federal court in Fergus Falls, Minnesota.

#### **17. FORCE MAJEURE**

Neither party to this Contract will be held responsible for delay or default caused by acts of God or other conditions that are beyond that party's reasonable control. A party defaulting under this provision must provide the other party prompt written notice of the default.

#### **18. SEVERABILITY**

If any provision of this Contract is found to be illegal, unenforceable, or void then both Sourcewell and Vendor will be relieved of all obligations arising under such provisions. If the remainder of this Contract is capable of performance, it will not be affected by such declaration or finding and must be fully performed.

## 19. PERFORMANCE, DEFAULT, AND REMEDIES

A. **PERFORMANCE.** During the term of this Contract, the parties will monitor performance and address unresolved contract issues as follows:

1. *Notification.* The parties must promptly notify each other of any known dispute and work in good faith to resolve such dispute within a reasonable period of time. If necessary, Sourcewell and the Vendor will jointly develop a short briefing document that describes the issue(s), relevant impact, and positions of both parties.
2. *Escalation.* If parties are unable to resolve the issue in a timely manner, as specified above, either Sourcewell or Vendor may escalate the resolution of the issue to a higher level of management. The Vendor will have thirty (30) calendar days to cure an outstanding issue.
3. *Performance while Dispute is Pending.* Notwithstanding the existence of a dispute, the Vendor must continue without delay to carry out all of its responsibilities under the Contract that are not affected by the dispute. If the Vendor fails to continue without delay to perform its responsibilities under the Contract, in the accomplishment of all undisputed work, any additional costs incurred by Sourcewell and/or its Members as a result of such failure to proceed will be borne by the Vendor.

B. **DEFAULT AND REMEDIES.** Either of the following constitutes cause to declare this Contract, or any Member order under this Contract, in default:

1. Nonperformance of contractual requirements, other than a Force Majeure event, or
2. A material breach of any term or condition of this Contract.

Written notice of default and a reasonable opportunity to cure must be issued by the party claiming default. Time allowed for cure will not diminish or eliminate any liability for liquidated or other damages. If the default remains after the opportunity for cure, the non-defaulting party may:

- Exercise any remedy provided by law or equity, or
- Terminate the Contract or any portion thereof, including any orders issued against the Contract.

## 20. INSURANCE

A. **REQUIREMENTS.** At its own expense, Vendor must maintain insurance policy(ies) in effect at all times during the performance of this Contract with insurance company(ies) licensed or authorized to do business in the State of Minnesota having an "AM BEST" rating of A- or better, with coverage and limits of insurance not less than the following:

1. *Workers' Compensation and Employer's Liability.*  
Workers' Compensation: As required by any applicable law or regulation.

Employer's Liability Insurance: must be provided in amounts not less than listed below:

Minimum limits:

\$500,000 each accident for bodily injury by accident

\$500,000 policy limit for bodily injury by disease

\$500,000 each employee for bodily injury by disease

2. *Commercial General Liability Insurance.* Vendor will maintain insurance covering its operations, with coverage on an occurrence basis, and must be subject to terms no less broad than the Insurance Services Office ("ISO") Commercial General Liability Form CG0001 (2001 or newer edition). At a minimum, coverage must include liability arising from premises, operations, bodily injury and property damage, independent contractors, products-completed operations including construction defect, contractual liability, blanket contractual liability, and personal injury and advertising injury. All required limits, terms and conditions of coverage must be maintained during the term of this Contract.

Minimum Limits:

\$1,000,000 each occurrence Bodily Injury and Property Damage

\$1,000,000 Personal and Advertising Injury

\$2,000,000 aggregate for Products-Completed operations

\$2,000,000 general aggregate

3. *Commercial Automobile Liability Insurance.* During the term of this Contract, Vendor will maintain insurance covering all owned, hired, and non-owned automobiles in limits of liability not less than indicated below. The coverage must be subject to terms no less broad than ISO Business Auto Coverage Form CA 0001 (2010 edition or newer).

Minimum Limits:

\$1,000,000 each accident, combined single limit

4. *Professional/Technical, Errors and Omissions, and/or Miscellaneous Liability.* During the term of this Contract, Vendor will maintain coverage for all claims the Vendor may become legally obligated to pay resulting from any actual or alleged negligent act, error, or omission related to Vendor's professional services required under this Contract.

Minimum Limits:

\$2,000,000 per claim or event

\$2,000,000 – annual aggregate

Failure of Vendor to maintain the required insurance will constitute a material breach entitling Sourcewell to immediately terminate this Contract for default.

B. **CERTIFICATES OF INSURANCE.** Prior to commencing under this Contract, Vendor must furnish to Sourcewell a certificate of insurance, as evidence of the insurance required under this Contract. Prior to expiration of the policy(ies), renewal certificates must be mailed to Sourcewell, 202 12th Street Northeast, P.O. Box 219, Staples, MN 56479 or sent to the Sourcewell Contract Administrator assigned to this Contract. The certificates must be signed by

a person authorized by the insurer(s) to bind coverage on their behalf. All policies must include there will be no cancellation, suspension, non-renewal, or reduction of coverage without thirty (30) days' prior written notice to the Vendor.

Upon request, Vendor must provide to Sourcewell copies of applicable certificates and endorsements, within ten (10) days of a request. Failure to request certificates of insurance by Sourcewell, or failure of Vendor to provide certificates of insurance, in no way limits or relieves Vendor of its duties and responsibilities in this Contract.

**C. ADDITIONAL INSURED ENDORSEMENT AND PRIMARY AND NON-CONTRIBUTORY INSURANCE CLAUSE.** Vendor agrees to name Sourcewell, including their officers, agents, and employees, as an additional insured under the Vendor's commercial general liability insurance policy with respect to liability arising out of activities, "operations," or "work" performed by or on behalf of Vendor, and products and completed operations of Vendor. The policy provision(s) or endorsement(s) must further provide that coverage is primary and not excess over or contributory with any other valid, applicable, and collectible insurance or self-insurance in force for the additional insureds.

**D. WAIVER OF SUBROGATION.** Vendor waives and must require (by endorsement or otherwise) all its insurers to waive subrogation rights against Sourcewell and other additional insureds for losses paid under the insurance policies required by this Contract or other insurance applicable to the Vendor or its subcontractors. The waiver must apply to all deductibles and/or self-insured retentions applicable to the required or any other insurance maintained by the Vendor or its subcontractors. Where permitted by law, Vendor must require similar written express waivers of subrogation and insurance clauses from each of its subcontractors.

**E. UMBRELLA/EXCESS LIABILITY.** Vendor confirms the limits required by this Contract can be met by either providing a primary policy or in combination with umbrella/excess liability policy(ies).

## **21. COMPLIANCE**

**A. LAWS AND REGULATIONS.** All Equipment, Products, or Services provided under this Contract must comply fully with applicable federal laws and regulations, and with the laws in the states and provinces in which the Equipment, Products, or Services are sold.

**B. LICENSES.** Vendor must maintain a valid status on all required federal, state, and local licenses, bonds, and permits required for the operation of the business that the Vendor conducts with Sourcewell and Members.

## **22. BANKRUPTCY, DEBARMENT, OR SUSPENSION CERTIFICATION**

Vendor certifies and warrants that it is not in bankruptcy or that it has previously disclosed in writing certain information to Sourcewell related to bankruptcy actions. If at any time during this Contract Vendor declares bankruptcy, Vendor must immediately notify Sourcewell in

writing.

Vendor certifies and warrants that neither it nor its principals are presently debarred, suspended, proposed for debarment, declared ineligible, or voluntarily excluded from programs operated by the State of Minnesota, the United States federal government, or any Member. Vendor certifies and warrants that neither it nor its principals have been convicted of a criminal offense related to the subject matter of this Contract. Vendor further warrants that it will provide immediate written notice to Sourcewell if this certification changes at any time.

### **23. PROVISIONS FOR NON-UNITED STATES FEDERAL ENTITY PROCUREMENTS UNDER UNITED STATES FEDERAL AWARDS OR OTHER AWARDS**

Members that use United States federal grant or FEMA funds to purchase goods or services from this Contract may be subject to additional requirements including the procurement standards of the Uniform Administrative Requirements, Cost Principles and Audit Requirements for Federal Awards, 2 C.F.R. § 200. Members may also require additional requirements based on specific funding specifications. Within this Article, all references to “federal” should be interpreted to mean the United States federal government. The following list only applies when a Member accesses Vendor’s Equipment, Products, or Services with United States federal funds.

A. **EQUAL EMPLOYMENT OPPORTUNITY.** Except as otherwise provided under 41 C.F.R. § 60, all contracts that meet the definition of “federally assisted construction contract” in 41 C.F.R. § 60-1.3 must include the equal opportunity clause provided under 41 C.F.R. §60-1.4(b), in accordance with Executive Order 11246, “Equal Employment Opportunity” (30 FR 12319, 12935, 3 C.F.R. §, 1964-1965 Comp., p. 339), as amended by Executive Order 11375, “Amending Executive Order 11246 Relating to Equal Employment Opportunity,” and implementing regulations at 41 C.F.R. § 60, “Office of Federal Contract Compliance Programs, Equal Employment Opportunity, Department of Labor.” The equal opportunity clause is incorporated herein by reference.

B. **DAVIS-BACON ACT, AS AMENDED (40 U.S.C. § 3141-3148).** When required by federal program legislation, all prime construction contracts in excess of \$2,000 awarded by non-federal entities must include a provision for compliance with the Davis-Bacon Act (40 U.S.C. § 3141-3144, and 3146-3148) as supplemented by Department of Labor regulations (29 C.F.R. § 5, “Labor Standards Provisions Applicable to Contracts Covering Federally Financed and Assisted Construction”). In accordance with the statute, contractors must be required to pay wages to laborers and mechanics at a rate not less than the prevailing wages specified in a wage determination made by the Secretary of Labor. In addition, contractors must be required to pay wages not less than once a week. The non-federal entity must place a copy of the current prevailing wage determination issued by the Department of Labor in each solicitation. The decision to award a contract or subcontract must be conditioned upon the acceptance of the wage determination. The non-federal entity must report all suspected or reported violations to the federal awarding agency. The contracts must also include a provision for compliance with the Copeland “Anti-Kickback” Act (40 U.S.C. § 3145), as supplemented by Department of Labor regulations (29 C.F.R. § 3, “Contractors and Subcontractors on Public Building or Public Work Financed in Whole or in Part by Loans or Grants from the United States”). The Act provides that each contractor or subrecipient must be prohibited from inducing, by any means, any person

13

employed in the construction, completion, or repair of public work, to give up any part of the compensation to which he or she is otherwise entitled. The non-federal entity must report all suspected or reported violations to the federal awarding agency. Vendor must be in compliance with all applicable Davis-Bacon Act provisions.

C. **CONTRACT WORK HOURS AND SAFETY STANDARDS ACT (40 U.S.C. § 3701-3708).** Where applicable, all contracts awarded by the non-federal entity in excess of \$100,000 that involve the employment of mechanics or laborers must include a provision for compliance with 40 U.S.C. § 3702 and 3704, as supplemented by Department of Labor regulations (29 C.F.R. § 5). Under 40 U.S.C. § 3702 of the Act, each contractor must be required to compute the wages of every mechanic and laborer on the basis of a standard work week of 40 hours. Work in excess of the standard work week is permissible provided that the worker is compensated at a rate of not less than one and a half times the basic rate of pay for all hours worked in excess of 40 hours in the work week. The requirements of 40 U.S.C. § 3704 are applicable to construction work and provide that no laborer or mechanic must be required to work in surroundings or under working conditions which are unsanitary, hazardous or dangerous. These requirements do not apply to the purchases of supplies or materials or articles ordinarily available on the open market, or contracts for transportation or transmission of intelligence. This provision is hereby incorporated by reference into this Contract. Vendor certifies that during the term of an award for all contracts by Sourcewell resulting from this procurement process, Vendor must comply with applicable requirements as referenced above.

D. **RIGHTS TO INVENTIONS MADE UNDER A CONTRACT OR AGREEMENT.** If the federal award meets the definition of "funding agreement" under 37 C.F.R. § 401.2(a) and the recipient or subrecipient wishes to enter into a contract with a small business firm or nonprofit organization regarding the substitution of parties, assignment or performance of experimental, developmental, or research work under that "funding agreement," the recipient or subrecipient must comply with the requirements of 37 C.F.R. § 401, "Rights to Inventions Made by Nonprofit Organizations and Small Business Firms Under Government Grants, Contracts and Cooperative Agreements," and any implementing regulations issued by the awarding agency. Vendor certifies that during the term of an award for all contracts by Sourcewell resulting from this procurement process, Vendor must comply with applicable requirements as referenced above.

E. **CLEAN AIR ACT (42 U.S.C. § 7401-7671Q.) AND THE FEDERAL WATER POLLUTION CONTROL ACT (33 U.S.C. § 1251-1387).** Contracts and subgrants of amounts in excess of \$150,000 require the non-federal award to agree to comply with all applicable standards, orders or regulations issued pursuant to the Clean Air Act (42 U.S.C. § 7401- 7671q) and the Federal Water Pollution Control Act as amended (33 U.S.C. § 1251- 1387). Violations must be reported to the Federal awarding agency and the Regional Office of the Environmental Protection Agency (EPA). Vendor certifies that during the term of this Contract will comply with applicable requirements as referenced above.

F. **DEBARMENT AND SUSPENSION (EXECUTIVE ORDERS 12549 AND 12689).** A contract award (see 2 C.F.R. § 180.220) must not be made to parties listed on the government wide exclusions

in the System for Award Management (SAM), in accordance with the OMB guidelines at 2 C.F.R. §180 that implement Executive Orders 12549 (3 C.F.R. § 1986 Comp., p. 189) and 12689 (3 C.F.R. § 1989 Comp., p. 235), "Debarment and Suspension." SAM Exclusions contains the names of parties debarred, suspended, or otherwise excluded by agencies, as well as parties declared ineligible under statutory or regulatory authority other than Executive Order 12549. Vendor certifies that neither it nor its principals are presently debarred, suspended, proposed for debarment, declared ineligible, or voluntarily excluded from participation by any federal department or agency.

G. **BYRD ANTI-LOBBYING AMENDMENT, AS AMENDED (31 U.S.C. § 1352).** Vendors must file any required certifications. Vendors must not have used federal appropriated funds to pay any person or organization for influencing or attempting to influence an officer or employee of any agency, a member of Congress, officer or employee of Congress, or an employee of a member of Congress in connection with obtaining any federal contract, grant, or any other award covered by 31 U.S.C. § 1352. Vendors must disclose any lobbying with non-federal funds that takes place in connection with obtaining any federal award. Such disclosures are forwarded from tier to tier up to the non-federal award. Vendors must file all certifications and disclosures required by, and otherwise comply with, the Byrd Anti-Lobbying Amendment (31 U.S.C. § 1352).

H. **RECORD RETENTION REQUIREMENTS.** To the extent applicable, Vendor must comply with the record retention requirements detailed in 2 C.F.R. § 200.333. The Vendor further certifies that it will retain all records as required by 2 C.F.R. § 200.333 for a period of three (3) years after grantees or subgrantees submit final expenditure reports or quarterly or annual financial reports, as applicable, and all other pending matters are closed.

I. **ENERGY POLICY AND CONSERVATION ACT COMPLIANCE.** To the extent applicable, Vendor must comply with the mandatory standards and policies relating to energy efficiency which are contained in the state energy conservation plan issued in compliance with the Energy Policy and Conservation Act.

J. **BUY AMERICAN PROVISIONS COMPLIANCE.** To the extent applicable, Vendor must comply with all applicable provisions of the Buy American Act. Purchases made in accordance with the Buy American Act must follow the applicable procurement rules calling for free and open competition.

K. **ACCESS TO RECORDS (2 C.F.R. § 200.336).** Vendor agrees that duly authorized representatives of a federal agency must have access to any books, documents, papers and records of Vendor that are directly pertinent to Vendor's discharge of its obligations under this Contract for the purpose of making audits, examinations, excerpts, and transcriptions. The right also includes timely and reasonable access to Vendor's personnel for the purpose of interview and discussion relating to such documents.

L. **PROCUREMENT OF RECOVERED MATERIALS (2 C.F.R. § 200.322).** A non-federal entity that is a state agency or agency of a political subdivision of a state and its contractors must comply



with Section 6002 of the Solid Waste Disposal Act, as amended by the Resource Conservation and Recovery Act. The requirements of Section 6002 include procuring only items designated in guidelines of the Environmental Protection Agency (EPA) at 40 C.F.R. § 247 that contain the highest percentage of recovered materials practicable, consistent with maintaining a satisfactory level of competition, where the purchase price of the item exceeds \$10,000 or the value of the quantity acquired during the preceding fiscal year exceeded \$10,000; procuring solid waste management services in a manner that maximizes energy and resource recovery; and establishing an affirmative procurement program for procurement of recovered materials identified in the EPA guidelines.

**24. CANCELLATION**

Sourcwell or Vendor may cancel this Contract at any time, with or without cause, upon sixty (60) days' written notice to the other party. However, Sourcwell may cancel this Contract immediately upon discovery of a material defect in any certification made in Vendor's Proposal. Termination of this Contract does not relieve either party of financial, product, or service obligations incurred or accrued prior to termination.

**Sourcwell**

DocuSigned by:  
By: Jeremy Schwartz  
C0FD2A139D06489...  
Jeremy Schwartz  
Title: Director of Operations & Procurement/CPO  
Date: 9/19/2019 | 12:15 PM CDT

**Cooper Lighting LLC**

DocuSigned by:  
By: Ken Walma  
BE75308E52164B9...  
Ken Walma  
Title: Vice President & General Manager  
Date: 9/19/2019 | 11:49 AM CDT

DocuSigned by:  
By: Chad Coquette  
7E42BBF817A64CC...  
Chad Coquette  
Title: Executive Director/CEO  
Date: 9/19/2019 | 9:35 AM CDT

## RFP #071619 - Sports Lighting with Related Supplies and Services

---

### Vendor Details

Company Name: EATON INDUSTRIAL CORPORATION  
Does your company conduct business under any other name? If yes, please state: Cooper Lighting LLC (76-0554120) / Ephesus Sports Lighting  
Address: 1121 HIGHWAY 74 SOUTH  
PEACHTREE CITY, GA 30269  
Contact: Gabriel Hough  
Email: GabeTHough@eaton.com  
Phone: 315-928-4773  
HST#: 31-1521120

### Submission Details

Created On: Monday July 15, 2019 15:28:19  
Submitted On: Tuesday July 16, 2019 12:58:11  
Submitted By: Gabriel Hough  
Email: GabeTHough@eaton.com  
Transaction #: 5374196a-cdf3-4720-a467-5d970d2656d4  
Submitter's IP Address: 192.104.67.221

---

Balance of Page Intentionally Left Blank

## Specifications

### Proposer Identity & Authorized Representatives

Line Item	Question	Response *
1	Proposer Legal Name (and applicable d/b/a, if any):	Cooper Lighting, LLC
2	Proposer Address:	125 East Jefferson Street Syracuse, NY 13202
3	Proposer website address:	www.ephesuslighting.com
4	Proposer's Authorized Representative (name, title, address, email address & phone) (The representative must have authority to sign the "Proposer's Assurance of Compliance" on behalf of the Proposer):	Gabriel Hough Strategic Sales Manager 125 East Jefferson Street Syracuse, NY 13202 GabeTHough@eaton.com 315-928-4773
5	Proposer's primary contact for this proposal (name, title, address, email address & phone):	Gabriel Hough Strategic Sales Manager 125 East Jefferson St Syracuse, NY 13202 GabeTHough@eaton.com 315-928-4773
6	Proposer's other contacts for this proposal, if any (name, title, address, email address & phone):	Michael Quijano Director of Business Development 125 East Jefferson St Syracuse, NY 13202 MichaelQuijano@eaton.com 315-579-2897

### Company Information and Financial Strength

Line Item	Question	Response *
7	Provide a brief history of your company, including your company's core values, business philosophy, and industry longevity related to the requested equipment, products or services.	Cooper Lighting LLC's Ephesus Sports Lighting brand was founded with the certainty that we can improve the world with lighting solutions that contribute to brighter, more vibrant, and more sustainable environments. Through our uncompromising commitment to innovative and insight-driven engineering, we provide the solutions and support to help people confidently create more positive and productive experiences in the places they live, work, and play.  The power of these ideas has helped us grow and expand; and in 2015, we were acquired by Eaton, a global leader in technology. Eaton shares our passion for innovative technology, and with the help of their reach and resources, our future is looking even brighter!
8	Provide a detailed description of the products and services that you are offering in your proposal.	Cooper Lighting LLC and Ephesus will be offering state of the art LED Sports Lighting fixtures, and project services that are industry leading in both technology and services. Cooper Lighting LLC will work with customers to initiate projects through retrofitting existing structures or through new structures. We will work with customers through our agency and integrator network to ensure that the customer experience from start to finish is second to none. Each Ephesus project will follow the guidelines of sound project management philosophy's from detailed photometric design, to quoting the appropriate bill of material, and working with 3rd party companies to implement the system in a cost and time effective manner.
9	What are your company's expectations in the event of an award?	Cooper Lighting LLCs realizes the enormous potential for LED adoption within Sourcewell Membership and will look to optimize our brand and Sourcewell recognition to deliver the customer experience expected of being an approved vendor. Cooper Lighting LLC will work with all Sourcewell Members that are looking to upgrade to LED Sports Lighting and make sure that each project is ran in a cost effective manner and efficiently implemented as needed.
10	Demonstrate your financial strength and stability with meaningful data. This could include such items as financial statements, SEC filings, credit and bond ratings, letters of credit, and detailed reference letters. Upload supporting documents (as applicable) in the document upload section of your response.	Cooper Lighting, LLC had revenues of over \$1.6B in 2018. It is a subsidiary of Eaton Corporation PLC, which is a publicly traded corporation under ENT on the NYSE. Eaton Corporation PLC had reported sales of \$21.6 Billion in 2018. Eaton acquired Cooper Lighting, LLC as part of Eaton's acquisition of Cooper Industries in 2012, and Cooper Lighting, LLC acquired the Ephesus Sports Lighting brand in 2015 as part of its acquisition of Ephesus Lighting, Inc. Public Financial Reports: <a href="https://www.eaton.com/us/en-us/company/investor-relations/investor-toolkit/financial-reports.html">https://www.eaton.com/us/en-us/company/investor-relations/investor-toolkit/financial-reports.html</a> <a href="https://www.nyse.com/quote/XNYS:ETN">https://www.nyse.com/quote/XNYS:ETN</a>

11	What is your US market share for the solutions that you are proposing?	Cooper Lighting LLC has been selling lighting products and solutions for over 100 years and has 15% of the US market share overall. Cooper Lighting LLC and Ephesus paved the way for the LED Sports Lighting Industry, leading the technological revolution for early adopters. We are the leaders when it comes to LED Sports Lighting. We share 20% of the overall market for Sports Lighting, and 35% of all LED Sports Lighting applications. We are constantly re-imagining the possibilities and will continue to set the trend with our dedication to R&D and NPI for the industry.
12	What is your Canadian market share, if any?	We have dedicated resources in sales and operations to service the Canadian Market. Cooper Lighting LLC has a long standing history within the market and the Ephesus brand own 18% of the Sports Lighting Market and 40% of the LED Sports Lighting Market in Canada. We continue to work with our existing agency and integrator partners to promote LED Sports Lighting.
13	Has your business ever petitioned for bankruptcy protection? If so, explain in detail.	Not applicable.
14	How is your organization best described: is it a manufacturer, a distributor/dealer/reseller, or a service provider? Answer whichever question (either a) or b) just below) best applies to your organization. a) If your company is best described as a distributor/dealer/reseller (or similar entity), provide your written authorization to act as a distributor/dealer/reseller for the manufacturer of the products proposed in this RFP. If applicable, is your dealer network independent or company owned? b) If your company is best described as a manufacturer or service provider, describe your relationship with your sales and service force and with your dealer network in delivering the products and services proposed in this RFP. Are these individuals your employees, or the employees of a third party?	Cooper Lighting LLC is a manufacturer with dedicated sales and operational employees that work directly for the Ephesus brand. We also have a third party agency and integrator network. Below is our regional breakdown for servicing customers.  The United States regions have been broken into West, Central, Gulf, Southeast and Northeast. Each of these regions has a support team consisting of a Business Development Manager (BDM), Project Manager (PM), Lighting Designer (LD), Inside Sales Representative (ISR) and Agents that develop and implement successful projects. The BDMs and Agents oversee creating relationships within the region while the inside support from the Lighting Designer, Project Manager and Inside Sales Representative create the blueprints, quotes, and construction plans to ensure smooth project implementation whether a site is new construction or retrofitting existing structures.  Cooper Lighting has strategic partnerships through contracted 3rd party agents and integrators that extend our customer service outreach. Through our agent and integrator network we work with end users and specifiers to drive project development to stimulate the market. Our network also provides the local on demand resources needed to successfully implement projects. Our integrator relationships have resulted in highly trained and qualified electrical contractors available throughout the country to help successfully deploy turnkey solutions.
15	If applicable, provide a detailed explanation outlining the licenses and certifications that are both required to be held, and actually held, by your organization (including third parties and subcontractors that you use) in pursuit of the business contemplated by this RFP.	Cooper Lighting LLC works with our contracted agency and integrator network throughout the project life cycle to ensure that all parties are properly certified and licensed to perform the expected work.
16	Provide all "Suspension or Disbarment" information that has applied to your organization during the past ten years.	Not applicable.
17	Within this RFP category there may be subcategories of solutions. List subcategory titles that best describe your products and services.	Fixtures/ Hardware/Entertainment Features/ Controls/ Services

### Industry Recognition & Marketplace Success

Line Item	Question	Response *
18	Describe any relevant industry awards or recognition that your company has received in the past five years	Ephesus Sports Lighting Brand: 2014 – First to light NFL stadium with LED 2015 – Introduced color temperature tuning and wireless control technology 2016 – First stadium and arena lit with RGB LED technology 2017 – Introduced beam tuning technology 2018 – Deployed Lumadapt sports lighting with instant upgrade capability
19	What percentage of your sales are to the governmental sector in the past three	Ephesus Sports Lighting sales to the government sector in the past three years account for 45% of revenue.
20	What percentage of your sales are to the education sector in the past three years	Ephesus Sports Lighting sales to the education sector in the past three years account for 30% of revenue.
21	List any state or cooperative purchasing contracts that you hold. What is the annual sales volume for each of these contracts over the past three years?	TIPS USA (Awarded Membership in 2019) - \$1M in Sales to Date Buy Boards (Awarded Membership 2019)
22	List any GSA contracts that you hold. What is the annual sales volume for each of these contracts over the past three years?	Not applicable

**References/Testimonials**

Line Item 23.

Entity Name *	Contact Name *	Phone Number *
Budweiser Events Center	Tom Manning	970-619-4115
War Memorial at OnCenter (Syracuse Crunch Hockey Club)	Jim Sarosy	345-473-4444 ext. 132
Nassau Coliseum/NYCB Live	Frank O'Brien	631-325-1940

**Top Five Government, Education or Non-profit Customers**

Line Item 24. Provide a list of your top five government, education, or non-profit customers (entity name is optional), including entity type, the state or province the entity is located in, scope of the project(s), size of transaction(s), and dollar volumes from the past three years.

Entity Name	Entity Type *	State / Province *	Scope of Work *	Size of Transactions *	Dollar Volume Past Three Years *
City of Chicago	Government	Illinois - IL	Provided designs, material and project management to upgrade city parks and rec to LED Sports Lighting.	\$50K -\$200K average	\$1.5M
City of Philadelphia	Government	Pennsylvania - PA	Provided designs, material and project management to upgrade city parks and rec to LED Sports Lighting.	\$50K-\$100K average	\$1.2 Million
Department of Defense- AirForce	Government	District of Columbia - DC	Provided designs, material and project management to upgrade bases with LED site lighting.	\$100K-\$1M average	\$7 Million
New York City	Government	New York - NY	Provided designs, material and project management to upgrade city parks and rec to LED Sports Lighting.	\$50K-\$100K average	\$1.5M
Department of Defense- Navy	Government	District of Columbia - DC	Provided designs, material and project management to upgrade bases with LED site lighting.	\$100K-\$250K average	\$1.5M

### Ability to Sell and Deliver Service to Sourcewell Members

Describe your company's capability to meet the needs of Sourcewell Members across the US, and Canada if applicable. Your response should address in detail at least the following areas: locations of your network of sales and service providers, the number of workers (full-time equivalents) involved in each sector, whether these workers are your direct employees (or employees of a third party), and any overlap between the sales and service functions.

Line Item	Question	Response *
25	Sales force.	The United States regions have been broken into West, Central, Gulf, Southeast and Northeast. Each regional has a Cooper Lighting LLC, Business Development Manager dedicated to stimulating the market. Each state and territory within each region also has a contracted territory agent that is dedicated to servicing the customers within their territory. A dedicated Cooper Lighting LLC Inside Sales Support Representative is there to help assist with customer service for both the BDM and agents within each state and region.
26	Dealer network or other distribution methods.	Cooper Lighting LLC uses contracted 3rd party agents and integrators throughout the US and Canadian markets. Each agent has sole rights to selling the Ephesus Sports Lighting products with in their territory and is supported by Cooper Lighting LLC sales and operational employees throughout the project process.
27	Service force.	Cooper Lighting LLC has a dedicated service team that is responsible for post-sale and installation customer satisfaction.
28	Describe in detail the process and procedure of your customer service program, if applicable. Include your response-time capabilities and commitments, as well as any incentives that help your providers meet your stated service goals or promises.	Our service department is dedicated to resolving warranty related issues within a timely manner.
29	Identify any geographic areas that you will NOT be fully serving through the proposed contract.	Cooper Lighting LLC will service all SourceWell Members within the United States and Canada.
30	Identify any Sourcewell Member sectors (i.e., government, education, not-for-profit) that you will NOT be fully serving through the proposed contract. Explain in detail. For example, does your company have only a regional presence, or do other cooperative purchasing contracts limit your ability to promote another contract?	Cooper Lighting LLC will service all SourceWell Members within the United States and Canada.
31	Define any specific contract requirements or restrictions that would apply to our Members in Hawaii and Alaska and in US Territories.	Cooper Lighting LLC will service all SourceWell Members within Hawaii, Alaska and in US Territories.

### Marketing Plan

Line Item	Question	Response *
32	Describe your marketing strategy for promoting this contract opportunity. Upload representative samples of your marketing materials (if applicable) in the document upload section of your response.	We plan to incorporate this contract into our pre-existing marketing strategies. At Cooper Lighting we are always marketing. The company realizes the importance of brand recognition and how the brand is being showcased and portrayed to potential customers. The direct employees of Cooper Lighting market the brand along with our contracted sales agents in their daily interactions within their regions. Cooper Lighting marketing utilizes traditional avenues including trade shows, conventions, printed media along with e-mail and phone campaigns. We hold sponsorships with MiLB, AHL, Spectra, SMG, IMG along with other various teams/organizations to leverage our position in the market place.
33	Describe your use of technology and digital data (e.g., social media, metadata usage) to enhance marketing effectiveness.	We have an online presence and take advantage of web press and media. We specifically market around when our existing customer venues are part of major sporting events such as the Final Four or Super Bowl. Cooper Lighting has a strong social media presence with LinkedIn and Twitter; where we share new technologies and specific projects when authorized to do so.
34	In your view, what is Sourcewell's role in pr Sourcewell- awarded contract into your sale	In our view, if a Sourcewell member is interested in an LED Sports Lighting project, we would want to be notified of an RFP, if not already actively engaged so that our products and services are in consideration for the project. We will actively promote our customers to have projects be processed through Sourcewell if awarded a contract.
35	Are your products or services available thr e- procurement system and how governmen	Not applicable.

### Value-Added Attributes

Line Item	Question	Response *
-----------	----------	------------

36	Describe any product, equipment, maintenance, or operator training programs that you offer to Sourcewell Members. Include details, such as whether training is standard or optional, who provides training, and any costs that apply.	Part of every LED Sports lighting project we offer is a training on how to use the new system. The technology and controls are advanced, but with an on-site/remote tutorial by one of our qualified project managers, end users can quickly adapt to using the new system. We also offer service contracts for light level verification and system level health monitoring for an additional annual fee.
37	Describe any technological advances that your proposed products or services offer.	<p><b>Integral Power :</b> Specifically designed and tested by Cooper Lighting for Ephesus technology, the integral driver is tested to rigorous standards at worst case ambient temperature (50C). Our integral power supply is the strongest component of our system in comparison to off-the-shelf power supplies that are used by all other sports lighting manufacturers. Our integral power ensures the best customer experience and takes full advantage of the benefits of LED solid-state technology.</p> <p><b>Thermal Isolation Plate:</b> The aluminum interface plate is located between the power supply and light head to create an air to thermally isolate the power supply from the light head. The purpose of this plate is to ensure the heat generated by the light head does not impact the power supply and vice versa to ensure highest luminaire reliability.</p> <p><b>LED and LED Heatsink:</b> The Chip on Board (COB technology) is the most highly reliable LED technology on the market today. The LED die is directly bonded to the substrate so there are no wire bonds or solder joints to wear out and fail catastrophically like other surface mount LEDs. Every other sports lighting manufacturer today is using surface mount technology, which makes their light heads the weakest link in the system and more susceptible to failure. The LED heatsink allows LEDs to operate at low temperate even in worst case ambient conditions. Thermal management of LEDs is critical for their long-term reliability and lumen maintenance. Our patented heatsink design ensures that the LED will continue to perform well beyond the warranty period.</p>
38	Describe any "green" initiatives that relate to your company or to your products or services, and include a list of the certifying agency for each.	<p>We care how we get our results just as much as the results themselves. Often, we talk about this as "Doing Business Right." Clear guidelines related to ethical behavior, safety requirements, and environmental practices are communicated to our employees worldwide.</p> <p>Many of our policies are outlined in our Corporate Social Responsibility Summary Document, which you can find at <a href="http://www.eaton.com/sustainability">www.eaton.com/sustainability</a>. This document summarizes our commitments regarding</p> <ul style="list-style-type: none"> <li>• Environment, Health, Safety, and Sustainability</li> <li>• Human Rights</li> <li>• Ethics &amp; Financial Integrity</li> <li>• Supply Chain</li> <li>• Reporting Improper Behavior</li> </ul> <p>Cooper Lighting's policy is that our operations be conducted in compliance with applicable environmental, health, and safety (EHS) laws and regulations, in keeping with good corporate citizenship and with a positive commitment to the protection of the natural and workplace environments.</p> <p>We engage with our suppliers on these issues as well. Cooper Lighting's supplier requirements and policies can be found at <a href="http://www.eaton.com/suppliers">www.eaton.com/suppliers</a>.</p> <p>We work hard on these topics and are pleased that we have received great recognition for this work. In 2015, Eaton was</p> <ul style="list-style-type: none"> <li>• Recognized as a leader among S&amp;P 500 companies on the CDP's Climate Disclosure Leadership Index for the seventh year.</li> <li>• One of Corporate Responsibility magazine's "100 Best Corporate Citizens," 2007-2015.</li> <li>• Ranked 22nd on the list of Top 500 Enterprises for China Corporate Social Responsibility 2015 for energy innovation and sustainable development.</li> <li>• Received a perfect score of 100 percent on the Human Rights Campaign Foundation's 2016 Corporate Equality Index (CEI).</li> </ul>
39	Identify any third-party issued eco-labels, ratings or certifications that your company has received for the equipment or products included in your Proposal related to energy efficiency or conservation, life-cycle design (cradle-to-cradle), or other green/sustainability factors.	We design and test our products to DLC (DesignLight Consortium) standards. Part of our NPI is getting our products certified DLC compliant.
40	Describe any Women or Minority Business Entity (WMBE), Small Business Entity (SBE), or veteran owned business certifications that your company or hub partners have obtained. Upload documentation of certification (as applicable) in the document upload section of your response.	Not applicable.

41	What unique attributes does your company, your products, or your services offer to Sourcewell Members? What makes your proposed solutions unique in your industry as it applies to Sourcewell members?	Cooper Lighting LLC is the technology leader in solid state LED Sports Lighting and offers unique product features that aren't offered by our competitors. We are the only company that offers an all in one product to the end user that has integrated Drivers/RGB/ Beam Tuning and Color Tuning as options. We build our fixtures to not only apply to white light sports lighting applications but to bring fan entertainment to the masses. We also offer web based health monitoring on a system level that allows facility/site operators to have the Intel and insight into their system at a push of button.
42	Identify your ability and willingness to provide your products and services to Sourcewell member agencies in Canada.	We currently service Canada and intend to continue to do so with the Sourcewell contract.

## Warranty

Describe in detail your manufacturer warranty program, including conditions and requirements to qualify, claims procedure, and overall structure. You may upload representative samples of your warranty materials (if applicable) in the document upload section of your response in addition to responding to the questions below.

Line Item	Question	Response *
43	Do your warranties cover all products, parts, and labor?	Cooper Lighting LLC offers the industry standard 10 year parts warranty. We work through third party agents and integrators that extend this coverage on the labor
44	Do your warranties impose usage restrictions or other limitations that adversely affect coverage?	Not applicable.
45	Do your warranties cover the expense of technicians' travel time and mileage to perform warranty repairs?	Cooper Lighting LLC standard warranty is for material only. If a labor warranty is purchased through a third party this is an optional adder at the time.
46	Are there any geographic regions of the United States (and Canada, if applicable) for which you cannot provide a certified technician to perform warranty repairs? How will Sourcewell Members in these regions be provided service for warranty repair?	Service and repair is not part of our standard warranty. It is offered as an additional option.
47	Will you cover warranty service for items made by other manufacturers that are part of your proposal, or are these warranties issues typically passed on to the original equipment manufacturer?	Third party materials that are part of our proposal are passed on to the original equipment manufacturer.
48	What are your proposed exchange and return programs and policies?	Our products are made to order, we do not accept returns.
49	Describe any service contract options for the items included in your proposal.	We offer post installation project management service contracts that cover light level verification and system level health monitoring. These are offered at an additional charge.

## Payment Terms and Financing Options

Line Item	Question	Response *
50	What are your payment terms (e.g., net 10, net 30)?	Net 60 - Customers Net 90 - Vendors
51	Do you provide leasing or financing options, especially those options that schools and governmental entities may need to use in order to make certain acquisitions?	Not applicable
52	Briefly describe your proposed order process. Include enough detail to support your ability to report quarterly sales to Sourcewell as described in the Contract template. For example, indicate whether your dealer network is included in your response and whether each dealer (or some other entity) will process the Sourcewell Members' purchase orders.	All orders are processed internally through Cooper Lighting LLC. If awarded a Sourcewell contract, we will create promo codes tracking each Sourcewell project and report according to the RFP for all contract applicable projects. We propose to pay 1% of the total purchase order to Sourcewell as part of the contract, we will pay this on a per project basis.
53	Do you accept the P-card procurement and payment process? If so, is there any additional cost to Sourcewell Members for using this process?	Not applicable.



**Pricing and Delivery**

Provide detailed pricing information in the questions that follow below. Keep in mind that reasonable price and product adjustments can be made during the term of an awarded Contract as described in the RFP, the template Contract, and the Sourcwell Price and Product Change Request Form.

Line Item	Question	Response *
54	Describe your pricing model (e.g., line-item discounts or product- ca materials (if applicable) in the document upload section of your res	Uploaded in the document section.
55	Quantify the pricing discount represented by the pricing proposal in this response. For example, if the pricing in your response represents a percentage discount from MSRP or list, state the percentage or percentage range.	5% discount off of MSRP for Sourcwell Members
56	Describe any quantity or volume discounts or rebate programs that you offer.	Not applicable.
57	Propose a method of facilitating "sourced" products or related services, which may be referred to as "open market" items or "nonstandard options". For example, you may supply such items "at cost" or "at cost plus a percentage," or you may supply a quote for each such request.	"Sourced" products or related services that aren't included on the pricing sheet uploaded in the document section will be entered at cost plus 15%
58	Identify any element of the total cost of acquisition that is NOT included in the pricing submitted with your response. This includes all additional charges associated with a purchase that are not directly identified as freight or shipping charges. For example, list costs for items like pre-delivery inspection, installation, set up, mandatory training, or initial inspection. Identify any parties that impose such costs and their relationship to the Proposer.	Pricing submitted includes all products and offerings at this time. Services not part of this submission and sourced at a later date by qualified parties, will result in the at cost plus 15% fee.  An exception to this is the cost of installation. The majority of our customers decide to hire this out on their own, we are typically a material only quote. We offer this service through integrators and include price not to exceed figures, within reason, on our pricing sheet uploaded in the documents section.
59	If freight, delivery, or shipping is an additional cost to the Sourcwell Member, describe in detail the complete freight, shipping, and delivery program.	Shipping is included on orders \$5,000 and above.
60	Specifically describe freight, shipping, and delivery terms or programs available for Alaska, Hawaii, Canada, or any offshore delivery.	Same applies for Canada and offshore US deliveries: shipping is included on orders \$5,000 and above.
61	Describe any unique distribution and/or delivery methods or options offered in your proposal.	Standard delivery options.

**Pricing Offered**

Line Item	The Pricing Offered in this Proposal is: *	Comments
62	c. better than the Proposer typically offers to GPOs, cooperative procurement organizations, or state purchasing departments.	

**Audit and Administrative Fee**

Line Item	Question	Response *
63	Specifically describe any self-audit process or program that you plan to employ to verify compliance with your proposed Contract with Sourcwell. This process includes ensuring that Sourcwell Members obtain the proper pricing, that the Vendor reports all sales under the Contract each quarter, and that the Vendor remits the proper administrative fee to Sourcwell.	If awarded a contract, Cooper Lighting LLC will work with Sourcwell staff when applicable to get purchasing compliance letters issued to customers during the quote to order stage. We will cross reference all issued pricing to make sure that Sourcwell Members receive their discounted rate. We will implement promo codes to track each order through our accounting system to keep a record of all member purchase orders and to ensure proper administrative fees are remitted to Sourcwell.
64	Identify a proposed administrative fee that you will pay to Sourcwell for facilitating, managing, and promoting the Sourcwell Contract in the event that you are awarded a Contract. This fee is typically calculated as a percentage of Vendor's sales under the Contract or as a per-unit fee; it is not a line-item addition to the Member's cost of goods. (See the RFP and template Contract for additional details.)	Upon awarded contract as an approved vendor, Cooper Lighting agrees to pay 1% of total purchase orders processed through Sourcwell on a per project basis. Sourcwell must provide purchasing compliance letters to Cooper Lighting LLC and Sourcwell members as a documented facilitator to receive 1% administrative fee.

## Industry Specific Questions

Line Item	Question	Response *
65	Describe the average life span of your sports lighting systems?	Our products are rigorously tested throughout the NPI development process and have an L70 rating of 100,000 hours or more.
66	Describe your process for evaluating on field and off site glare for your sports lighting products?	We have an entire paper dedicated to how we address glare in solid-state lighting that can be <a href="#">Addressing- Glare.pdf</a>
67	How many LED sports lighting fixtures, within approx. 1,000 fixtures, do you currently have installed in the marketplace?	We currently have approximately 150,000 LED Sports Lighting Fixtures in the marketplace today.
68	Are there any additional or on-going fees in regards to the operation of your lighting control system?	We offer entertainment features that have the option of being purchased on a monthly basis.
69	If you are awarded a contract, provide a few examples of internal metrics that will be tracked to measure whether you are having success with the contract.	Promo codes will track each project and we will look at the overall Sourcewell member purchase orders on a bi-annual basis to review success of the contract.

### Exceptions to Terms, Conditions, or Specifications Form

Only those Proposer Exceptions to Terms, Conditions, or Specifications that have been accepted by Sourcewell have been incorporated into the contract text

### Documents

#### Ensure your submission document(s) conforms to the following:

- Documents in PDF format are preferred. Documents in Word, Excel, or compatible formats may also be provided.
- Documents should NOT have a security password, as Sourcewell may not be able to open the file. It is your sole responsibility to ensure that the uploaded document(s) are not either defective, corrupted or blank and that the documents can be opened and viewed by Sourcewell.
- Sourcewell may reject any response where any document(s) cannot be opened and viewed by Sourcewell.
- If you need to upload more than one (1) document for a single item, you should combine the documents into one zipped file. If the zipped file contains more than one (1) document, ensure each document is named, in relation to the submission format item responding to. For example, if responding to the Marketing Plan category save the document as "Marketing Plan."
  - Financial Strength and Stability (optional)
  - Marketing Plan/Samples (optional)
  - WMBE/MBE/SBE or Related Certificates (optional)
  - [Warranty Information](#) - Ephesus-Standard-Warranty-0518A.pdf - Tuesday July 16, 2019 10:04:06
  - [Pricing](#) - Sourcewell Pricing Sheet RFP071619.pdf - Tuesday July 16, 2019 10:08:41
  - [Additional Document](#) - Ephesus RFP Reponse\_Sourcewell RFP071619.pdf - Tuesday July 16, 2019 12:54:58

**AMENDMENT #1  
TO  
CONTRACT #071619-CPL**

THIS AMENDMENT is by and between **Sourcewell**, 202 12th Street Northeast, P.O. Box 219, Staples, MN 56479 (Sourcewell) and **Cooper Lighting LLC**, 125 East Jefferson Street, Syracuse, NY 13202 (Vendor).

Vendor was awarded a Sourcewell Contract for Sports Lighting with Related Supplies and Services effective September 19, 2019, until August 27, 2023, relating to the provision of services by Vendor and to Sourcewell and its Members (Original Contract).

In the first quarter of 2020, Signify N.V. acquired Cooper Lighting from Eaton. This acquisition does not affect the ability of Vendor to maintain its contract with Sourcewell, but certain references within the Original Contract to Eaton should now be read and referred to Signify.

The parties agree that certain terms within the Original Contract will be amended, but only to the extent as hereunder provided.

IN CONSIDERATION OF the mutual covenants and agreements described in this Amendment, the parties agree as follows:

1. This Amendment is effective upon the date of the last signature below.
2. The reference in the Original Contract to "Eaton Industrial Corporation" should be omitted and replaced with "Signify North America Corporation."
3. All references in the Original Contract to the e-mail address of Gabe Hough will be replaced with gabe.hough@cooperlighting.com.
4. All references in the Original Contract to the e-mail address of Michael Quijano will be replaced with michael.quijano@cooperlighting.com.

**Remainder of page intentionally left blank.**

- 5. The e-mail address referenced in Article 2. Equipment, Products, or Services, F. Warranty Activation/Service Claims, is deleted and replaced with the following: Ephesuswarranty@cooperlighting.com, and the telephone number is deleted and replaced with: 800-573-3600.

IN WITNESS WHEREOF, the parties have executed this Amendment.

**Sourcewell**

DocuSigned by:  
By: Jeremy Schwartz  
Auth: C0FD2A139D06489

Jeremy Schwartz  
Name – Printed

Title: Director of Operations & Procurement/CPO

Date: 4/27/2020 | 12:23 PM CDT

**Cooper Lighting LLC**

By: [Signature]  
Authorized Signature

Kraig Kasler  
Name – Printed

Title: President

Date: April 27, 2020

**Sourcewell-APPROVED:**

DocuSigned by:  
By: Chad Coauette  
Auth: 7E42B8F817A64CC

Chad Coauette  
Name – Printed

Title: Executive Director/CEO

Date: 4/27/2020 | 1:22 PM CDT



*S P O R T S L I G H T I N G*

***NEVER GIVE UP.***

FEATURING  ephesus

**Networked LED Sports Lighting Informative Packet  
Prepared for Panama City Beach Parks and Recreation  
January 09, 2023**





January 09, 2023

**Cheryl Joyner**  
**Director – Parks & Recreation**  
**16200 Panama City Beach Pkwy.**  
**Panama City Beach, FL 32413**

**FR: Ivy J. Davis, Jr. / Mike Lorenz NGU Sports Lighting, LLC.**

**Sourcewell Contract Number: 071619-CPL (Cooper Lighting, LLC).**

**RE: Networked LED Sports Lighting Informative Packet for Panama City Beach Parks & Recreation Department (Frank Brown Park)**

Panama City Beach Parks & Recreation Department (PCB) has expressed interest in learning more the about our networked LED sports lighting solutions. NGU is pleased to provide you with an offer of business for the Frank Brown Park located in Panama City Beach, FL.

NGU will provide a new, solid-state LED sports lighting system for the festival grounds. NGU intends to provide a turnkey system with material, installation, and project management services. This system will incorporate a wireless communication system (AirMesh) with remote control programming for up to eight standard or dynamic scenes and includes operational training.

The new system will utilize the Lumasport 8 fixture, mounting hardware, AirMesh wireless control system, and a 10-year equipment and service warranty (including yearly maintenance) covering the LED fixtures.

**Bill OF Material**

***Festival Park***

PART	DESCRIPTION	QUANTITY	LEAD TIME
Fixture	Lumasport-8 (640 LED Watts)	131	8-10 weeks
Poles & Cross arms	60' direct embedded steel poles & prewired cross arms with drop cables & distribution boxes	17	
Lighting Design	Stamped and signed foundation	1	
Controls	Air Mesh Hub	1	
Warranty	10-years (Parts & Service)	1	
Construction Time		1	8 weeks

**Program Highlights**

**Comprehensive project management: FPL Energy Services will provide project management services and work with NGU throughout the planning, implementation and completion phases of the project to ensure project execution exceeds expectations.**



- Complete support throughout all project phases: Our project management process will be transparent, and PCB can expect our best-in-class service; including photometric lighting design.
- **Full Lighting Control:**
  - 120VAC Air Mesh Hub (Includes Dynamic Scenes Firmware Package)
  - Full training of personnel on new system provided by NGU.
- **Maintenance convenience:**
  - Under our contract, NGU is responsible for maintenance costs for 10 years,
- **Timeline:**
  - LED conversions will be replaced within months from signing contract; materials will be on-site within 10 weeks.
- **Provide and install all necessary labor, materials, and equipment required for a complete replacement of fixtures**
  - Demolition and proper disposal/recycling of existing lamp and fixtures

### **Program Highlights**

**LED SPORTS LIGHTING Program (Festival Area)** – to include, but not limited to the following:

- Full lighting audit of service area
  - Aiming of the fixtures
- Removal and disposal of existing fixtures
- Installation of new LED lighting fixtures
- Installation of new poles (Festival Park), cross arms and fixtures per design(s) including mounting hardware, where applicable. Underground electrical (trenching, conduit, wiring) for new and shifted pole locations included.
- Installation of wireless communication system (AirMesh)
  - Includes remote programming for up to eight lighting scenes
- Project management services by FPLES, including coordination with the customer
- Commissioning of fixtures
- End-user controls training
- 10-Year product warranty on Fixtures
- 10-Year maintenance coverage

### **Program Pricing:**

MSRP: \$ 1,155,000.00

PCB Pricing: **\$ 1,097,250.00**



## **System Benefits**

The system has the following key benefits:

- **Operational Efficiency** - The Lumaspport system generates over 140 lumens of light per watt of power – making it the most energy efficient sports system in the marketplace.
- **System Reliability** – Designed and manufactured to the highest reliability standards in the marketplace – the Lumaspport is a dual driver system. Simply put – if one driver fails the fixture will maintain luminance. The system also uses chip on board innovation which has a much higher performance reliability than the soldered LED chip method used by other manufacturers.
- **Ease of installation** – FPLES will fully support you in your installation efforts by providing a qualified project manager to give you the necessary information to be successful. Our system will come prewired, pre-installed and pre aimed.
- Approximately 25% more efficient than the current system
- Wide range of capabilities through control system
- Internal patented glare control optics
- High CRI

### **Pricing Notes:**

- o Pricing above is valid for 60 days from quote delivery date
- o Payment terms: 50% net 10 days after order; 35% net 10 days after material shipped. 15% net 30 after system is installed
- o Implementation of contracting through SourceWell.
- o Pricing does not include sales or use tax
- o Poles have been designed to 150 mph AASHTO 2013. If there are other city/county building codes to adhere to, please advise and pricing will adjust accordingly.
- o Foundation design(s) required. We base the design on *owner provided* geotechnical reports/soil boring logs.
- o Installation does not account for subsurface issues such as shallow water table, hitting concrete or metal objects, slurry drilling conditions.
- o Permitting, or other local ordinance project-related fees are omitted,

## **Conclusion**

NGU's Sports Lighting Networked LED LaaS program utilizes our existing construction and maintenance infrastructure, along with our LED lighting supply chain, to convert your current sports lighting system at Frank Brown Park to a proposed 131 lighting fixture system (Festival Park), including new poles for the festival area – within an estimated five-month period (from contract award). The execution of the contract will be through the Sourcewell platform to aid in the procurement process for PCB reflecting over a **5% savings** from the MSRP. Lastly, by utilizing the proposed lighting system, PCB would implement a system that is roughly 25% more efficient than your current system.



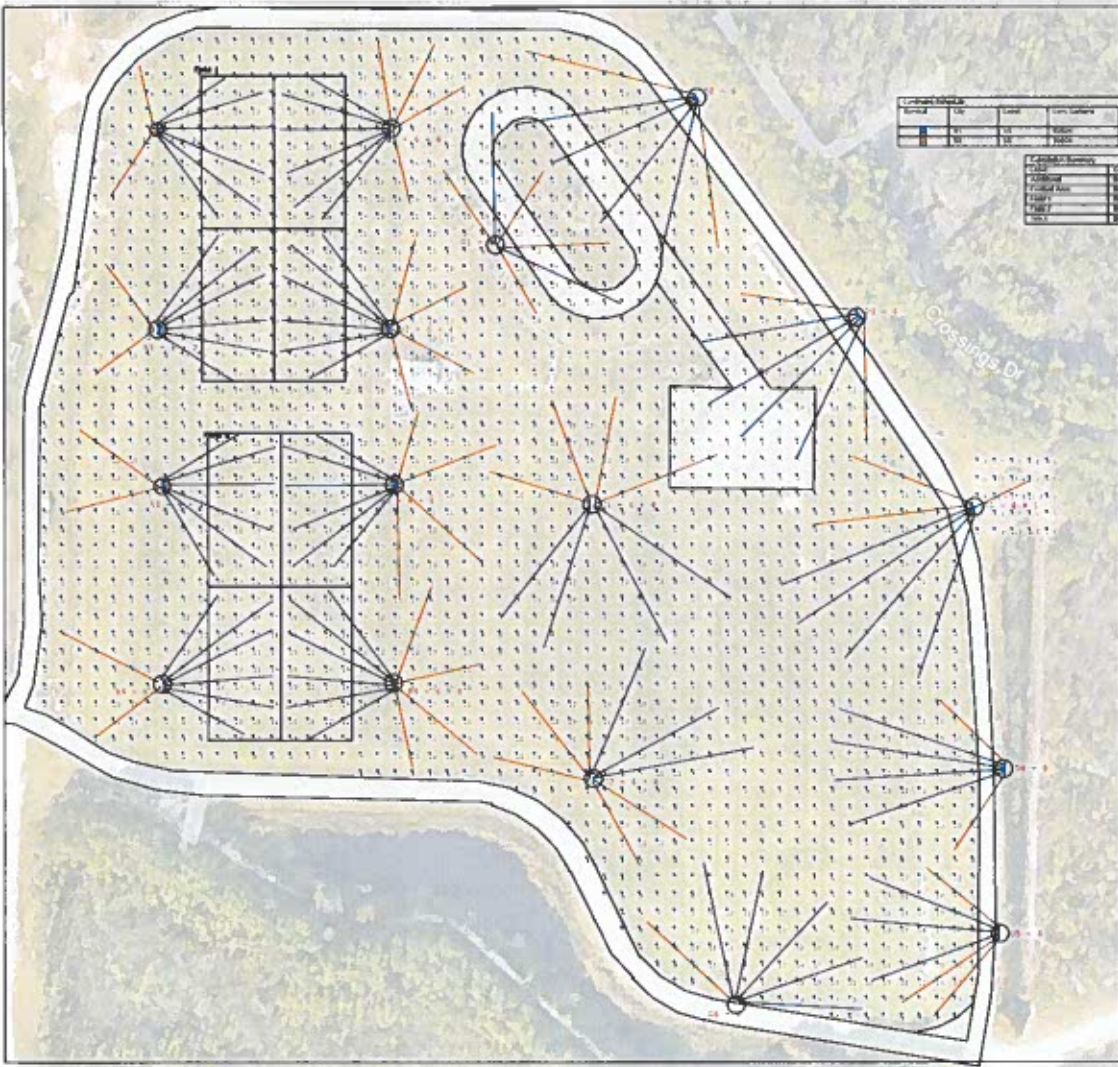

Symbol	Qty	Location	Comments	Height	Notes	Material	Notes
1	17	Various	Poles	60' / 80'			

Category	Item	Qty	Unit	Notes
Poles	60' Pole	10		
	80' Pole	7		
Wiring	Conduit	100	ft	
	Wire	100	ft	

- A1 - A4 @ 80' @ FRONT - 3 BACK
  - B1 - B4 @ 80' @ FRONT - 4 BACK
  - C1 - C2 @ 80' @ FRONT - 4 BACK
  - D1 - D2 @ 60' @ FRONT - 4 BACK
  - E1 - E2 @ 60' @ FRONT - 1 BACK
- 17 POLES TOTAL AT 60'



**THIS IS NOT A CONSTRUCTION DOCUMENT**  
 THIS DRAWING IS THE PROPERTY OF NGU SPORTS LIGHTING, INC. IT IS NOT TO BE REPRODUCED OR TRANSMITTED IN ANY FORM OR BY ANY MEANS, ELECTRONIC OR MECHANICAL, INCLUDING PHOTOCOPYING, RECORDING, OR BY ANY INFORMATION STORAGE AND RETRIEVAL SYSTEM, WITHOUT THE WRITTEN PERMISSION OF NGU SPORTS LIGHTING, INC. THE USER OF THIS DRAWING IS TO ACCEPT THE RESPONSIBILITY OF THE USER TO VERIFY THE ACCURACY OF THE INFORMATION PROVIDED HEREIN AND TO BE RESPONSIBLE FOR ANY ERRORS OR OMISSIONS. NGU SPORTS LIGHTING, INC. IS NOT RESPONSIBLE FOR ANY ERRORS OR OMISSIONS. THE USER OF THIS DRAWING IS TO ACCEPT THE RESPONSIBILITY OF THE USER TO VERIFY THE ACCURACY OF THE INFORMATION PROVIDED HEREIN AND TO BE RESPONSIBLE FOR ANY ERRORS OR OMISSIONS. NGU SPORTS LIGHTING, INC. IS NOT RESPONSIBLE FOR ANY ERRORS OR OMISSIONS.

**NGU**  
 SPORTS LIGHTING  
**NEVER GIVE UP**  
 Passion and Commitment exclusively for Eprvue LED Sports Lighting

3401 PGA Blvd. Suite 110  
 Palm Beach Gardens, FL 33410  
 www.ngusportslighting.com  
 Phone: 1-888-NGU-LED

**FESTIVAL PARK**  
**PANAMA CITY BEACH**  
 20 AVERAGE FC FOOTBALL , 10 FC OTHER  
 ALL LUMINAIRES AT 60'

DESIGNED BY H. JOHNSON, LC	DATE 12/6/2022	SCALE 1" = 80'	DRAWING NUMBER LD22533E
-------------------------------	-------------------	-------------------	----------------------------

Project	Catalog #	Type
Prepared by	Notes	Date

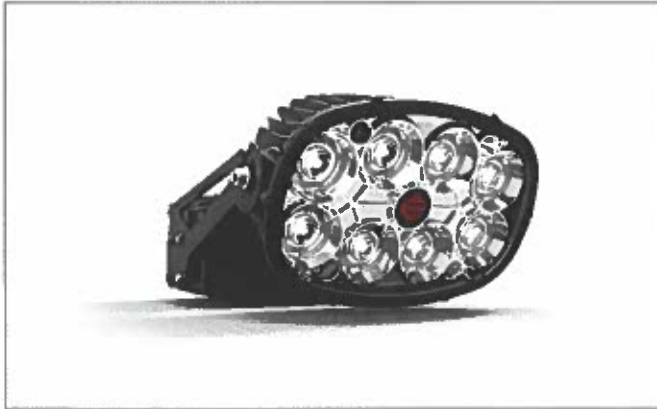

# Ephesus

## LUMASPORT 8

White LED Sports & Entertainment Luminaire

### Typical Applications

Pro Arenas • University & Collegiate Arenas • University & Collegiate Stadiums • Multi-Event & Convention Centers • Gymnasiums & Field Houses

### Interactive Menu

- Dimensional Details [page 1](#)
- Ordering Information [page 2](#)
- Dimensional and Mounting Details [page 3](#)
- Visor (VHE) Configuration [page 4](#)
- Performance Data [page 5](#)
- Optical Performance Data [page 6](#)
- Ordering Information for Accessories [page 8](#)
- Accessory Dimensions and Part Details [page 9](#)
- Example System Topology [page 12](#)

### Product Certification



### Top Product Features

- 55,000 or 90,000 lumen output options
- Glare and cutoff control via Hybrid Reflector and TIR Optical System
- Reduce install time with pre-aimable two-piece assembly
- Virtually eliminate maintenance with power redundancy
- Industry leading light source reliability with Chip-on-Board LEDs
- Greater than 92% lumen maintenance at 55,000 hours
- Wireless AirMesh, Wired DMX or sACN controls options to suit your needs
- [Impact Resistant Glass](#) option protects from vandalism and prevents down time in the event of impact to the glass.

### Dimensional Details

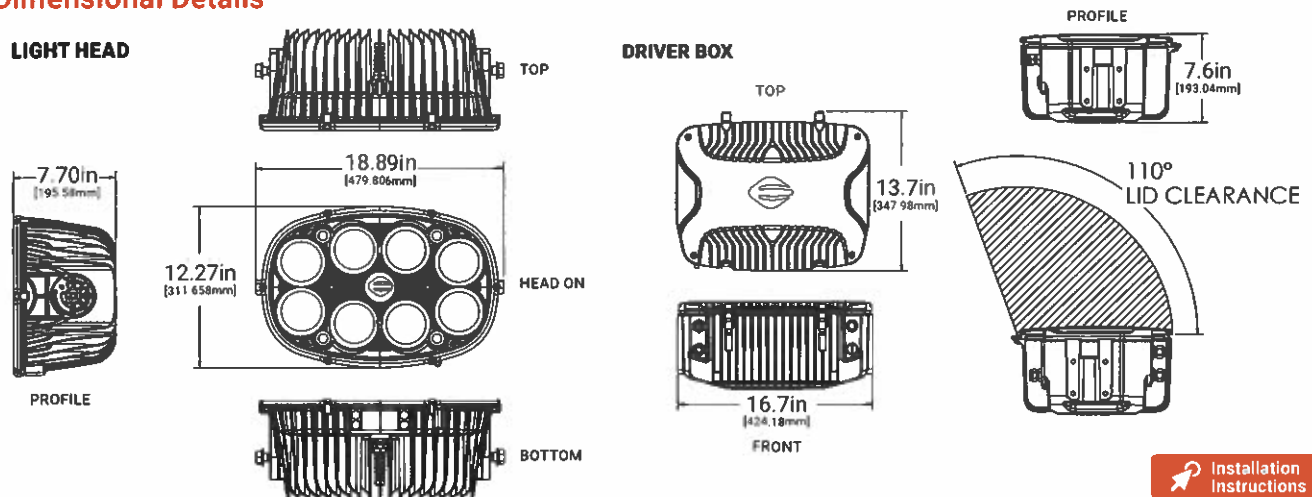

Order Information

NOTE: A complete fixture order requires a selection entry for Brand, Family, Model, Power Configuration, Color, CCT, CRI, Optic, Light Head Cable (DC), Voltage, Control, Mount Configuration, Power Cable (AC), Options, Packaging, & International Option.

SAMPLE ORDER NUMBER: EPH-LS-08-0320L-BLK-40-70-1S-C04-HV-LB-LY-A00-HEG-BP-ST

Brand	Family	Model	Power Configuration	Color	CCT	CRI	Optic	Light Head Cable (DC)
EPH = Ephesus	LS = Lumasport	08 = 8 Optics	0320L = 320W Local Power <sup>1</sup> 0640L = 640W Local Power <sup>1</sup>	BLK = Black WHT = White	40 = 4000K 50 = 5000K 57 = 5700K	70 = 70 CRI 80 = 80 CRI	1S = NEMA 3   17.5   33.3 2S = NEMA 3   21.9   40.2 3S = NEMA 3   25.4   45.7 4S = NEMA 4   36.0   64.4 5S = NEMA 5   46.6   82.6 7F* = NEMA 7   72.5   131.0	C04 = 4ft Cable, Standard C10* = 10ft Cable, Catwalk Bracket
			Notes: (1) Local Power means that the light head is attached to the driver box with the yoke or pendant mount.	Notes: (2) Not coastal rated. Contact Ephesus for coastal fixture options.			Notes: (3) Optic = NEMA TYPE, BEAM ANGLE, FIELD ANGLE. Additional optical performance data within spec sheet.  (4) 7F = NEMA 7 Optic only available with 0320L = 320W Local Power configuration.	Notes: (5) DC Cable connecting the light head to the driver box  (6) C10 = 10ft Cable is intended to be used with the Ephesus Catwalk Bracket

Voltage	Control	Mount Configuration	Power Cable (AC)	Options	Packaging	International Option
LV = Low Voltage HV = High Voltage	NC = No Control AM = Wireless AirMesh LB = Wired DMX	LY = Local Yoke LP = Local Pendant	A00 = No Cable, Standard A04 = 4ft Cable A10 = 10ft Cable A15 = 15ft Cable	HEG = No Visor VHE = Visor IRG = No Visor WIR = Visor  High Efficiency Glass Lens High Efficiency Glass Lens Impact Resistant Glass Lens Impact Resistant Glass Lens	BP = Bulk Pack	ST = Standard
			Notes: (7) AC Cable connecting the Driver Box to the electrical power source.			

DesignLights Consortium® Qualified. Refer to [www.designlights.org](http://www.designlights.org) Qualified Products List under Family Models for details

Dimensional and Mounting Details

MOUNTING: DRIVER BOX

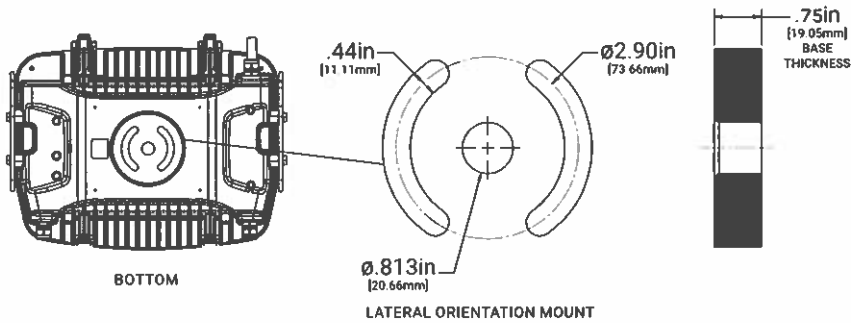

MOUNTING CONFIGURATION: LOCAL YOKE

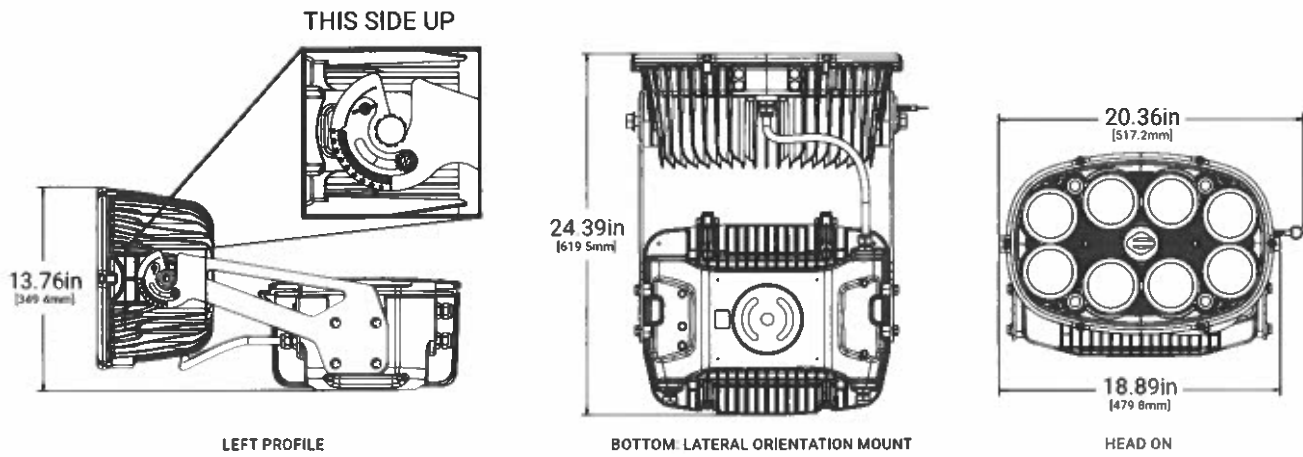

MOUNTING CONFIGURATION: LOCAL PENDANT

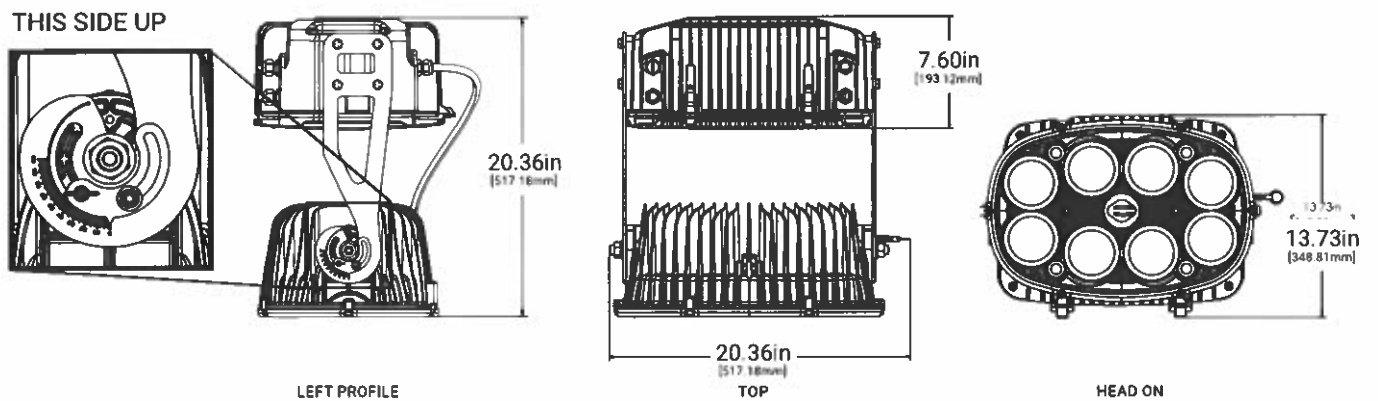

VHE & VIR Visor Option

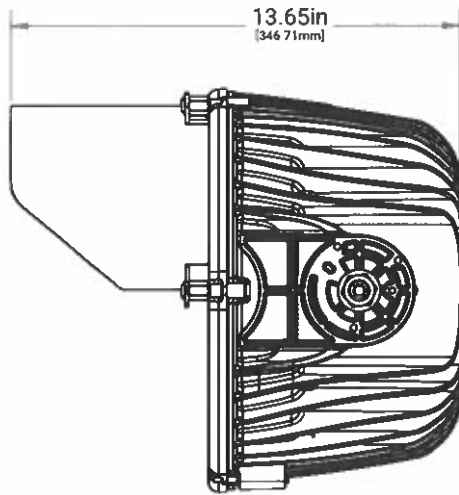

LEFT PROFILE: VISOR

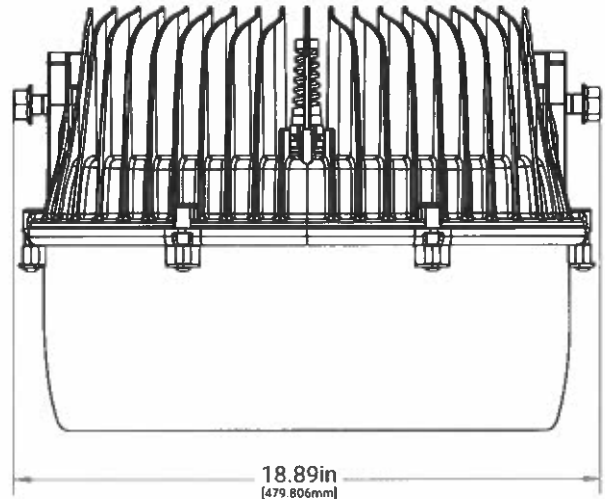

TOP: VISOR

NOTES:

The addition of a visor adds 1lb of material to the luminaire weight.

## Performance Data<sup>1</sup>

	LUMASPORT 8 (320W)	LUMASPORT 8 (640W)
Lumen Output Range <sup>2</sup>	48,303 - 55,419lm	80,572 - 92,929lm
Nominal Power <sup>2</sup>	340W	680W
Input Voltage (Low Voltage)	120-277VAC	120-277VAC
Input Voltage (High Voltage)	347-480VAC	347-480VAC
Efficacy Range <sup>2</sup>	140.4 - 163.5 lm/W	117.5 - 139.3 lm/W
CRI <sup>4</sup>	70, 80	70, 80
TLCI <sup>4</sup>	75	75
CCT Range	4000K, 5000K, 5700K	4000K, 5000K, 5700K
Distribution (NEMA)	3-5, 7	3-5
Dimming Range	DIM TO OFF, 10%-100%	DIM TO OFF, 10%-100%
Operating Temperature Range	-40°C to +40°C	-40°C to +40°C
Usage	INDOOR, OUTDOOR*	INDOOR, OUTDOOR*
Mounting Options (3G RATED)	LOCAL YOKE, LOCAL PENDANT	LOCAL YOKE, LOCAL PENDANT
Electrical Certifications	FCC, UL8750, UL1598, DLC Standard (NANQSV)	FCC, UL8750, UL1598, DLC Standard (NANQSV)
Environmental Certifications	ANSI C136.31-2010 3G, IP66, NEMA4X <sup>7</sup>	ANSI C136.31-2010 3G, IP66, NEMA4X <sup>7</sup>
Surge	10kV	10kV
Effective Projected Area (EPA)	1.8 (sq. ft.)	1.8 (sq. ft.)
Effective Projected Area (EPA) with Visor (VHE) <sup>8</sup>	1.8 - 2.5 (sq. ft.)	1.8 - 2.5 (sq. ft.)
Approximate Weight <sup>9</sup>	67.5 LBS	71.5 LBS

### NOTES:

- (1) Specifications are subject to change without notice
- (2) Refer to Optical Performance Data
- (3) Values are +/- 4% when fixture is operated at 25°C ambient
- (4) Values are +/- 2%
- (5) Values are +/- 3 points
- (6) When driver box is mounted in upright position
- (7) Light head meets NEMA4X Certification
- (8) EPA may vary depending on the aiming angle of the fixture
- (9) Weight may vary depending on mounting bracket, VHE Visor option, light head and driver box selection.

## Electrical Performance Data

Product	Input Voltage Range (VAC)	Nominal Input Power (W)	Input Current (A)	Power Factor (>60% Load)	THD (>60% Load)	Inrush (A2s)	Inrush period (ms)	Peak Inrush (A)
LS-8-320	120-277	340 (365 Max)	1.3 - 3.0 (4.0 Max)	> 0.9	< 20%	1.9	3.52	150
	347-480	340 (365 Max)	0.7 - 1.0 (1.5 Max)	> 0.9	< 20%	3.87	1.77	70
LS-8-640	120-277	680 (740 Max)	2.5 - 5.9 (8.0 Max)	> 0.9	< 20%	3.8	3.52	300
	347-480	680 (740 Max)	1.5 - 2.0 (3.0 Max)	> 0.9	< 20%	7.74	1.77	140

Project	Catalog #	Type
Prepared by	Notes	Date



# Ephesus

## AirMesh Hub

### Wireless Lighting System Controls

#### Typical Indoor/Outdoor Applications

- Professional Stadiums & Arenas • University/Collegiate Stadiums & Arenas
- K-12 Stadiums & Arenas • Game Fields • Practice Fields • Multi-use Recreational & Municipal Fields • Public Assembly & Convention Centers
- Gymnasiums & Field Houses • Unmanned Sports Facilities

#### Interactive Menu

- AirMesh Hub [page 1](#)
- Product Overview [page 2](#)
- Dynamic Scenes [page 3](#)

#### Product Certification



#### Top Product Features

- Can be installed anywhere you need wireless, push-button control
- Five-button, pre-programmed switch provides easy control of all lights at specified dimming levels (0%, 25%, 50%, 75%, 100%)
- Can communicate via LAN connection, Wi-Fi, or through a cellular network\*
- Weather-protected for outdoor venues
- Includes internal surge protection
- Enables Static and Dynamic Scenes

#### Dimensional Details

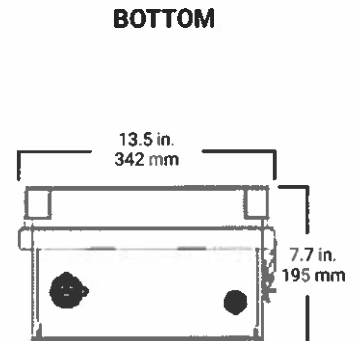
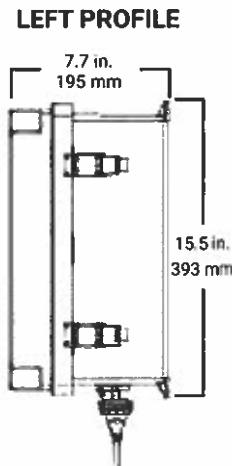
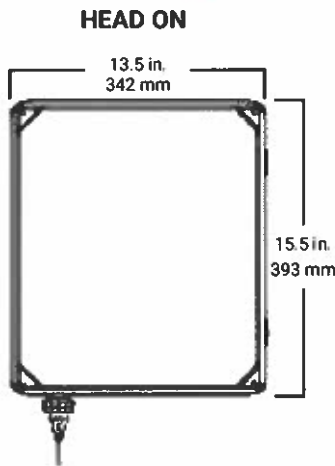

Due to our continuous improvement efforts, specifications are subject to change without notice.  
\*Cellular and/or data charges may apply



## Product Overview

The AirMesh Hub is an Ephesus component that can be installed anywhere you need wireless push-button lighting control, such as municipal ballparks, hockey arenas, basketball facilities, and other multi-use complexes. The AirMesh Hub is easy for certified electricians to install in both indoor and outdoor applications that's contained in the NEMA 4X enclosure. The 5-button 25 scenes (5 per button) controller allow for local manual access to facility lighting across specific zones or over the entire lighting installation. The AirMesh Hub enables quick and simple access to a switch station that can be programmed with unlimited options to meet the needs of the end-user.

## AirMesh Hub Specifications

Dimensions	15.5" x 13.5" x 7.7" (393 x 342 x 195 mm)
Input Power	Outdoor rated power supply 90-120VAC; 8W max, 6kV surge protection
Operating Environment	Outdoor rated at -20°C to +55°C, IP65 (when latched)
Cellular	Verizon 4G LTE
Wi-Fi	802.11 b/g/n
Radio	SNAP 2.4GHz 802.15.4 Wi-Fi 2.4GHz 802.11 b/g/n
Certifications	FCC/IC; Tested to CAN/CSA C22.2 No. 60950-1/A2:2014 and UL 60950-1/R:2014-10
Ratings	IP65 <sup>1,2</sup>

## AirMesh Function

AirMesh Function	Description
Maximum number of lights controlled by hub	Up to 1000
Maximum distance of fixture from location of hub	500 feet
Maximum allowable distance from one fixture to next	500 feet
Maximum number of programmable pre-set scenes	25 (5 per button)
Individual light control	Preprogrammed via 5-button hub. Additional scenes and light control obtained via web interface with hub
Health monitoring <sup>3</sup>	Real-time monitoring of lighting status at the fixture and system level, outage notifications, storage of power consumption, temperature and other system parameters which can be retrieved for later analysis <sup>4</sup>
Remote Connectivity	Web interface can be accessed by direct Wi-Fi connection or through internet via Ethernet or built-in cellular <sup>5</sup>
Alerts	Email alerts available when connected to internet via Ethernet or built-in cellular <sup>5</sup>
Users	User and administrative accounts with multiple permission levels available
Sensors	Voltage-sourcing sensors can be added to the system to turn lights on/off with daylight or occupancy sensors. Multiple output levels in response to light sensors (daylight harvesting)
Map View	Ability to view light state (on/off/ alarm) in graphical map/satellite view
Scheduling	Ability to schedule recurring events at fixed times or based on astronomical clock
Compatibility	Ability to add control modules to existing lighting fixtures to add Air-Mesh functionality to entire facility

**Notes**  
 Due to our continuous improvement efforts, specifications are subject to change without notice.  
<sup>1</sup>In maintain IP rating of the unit, it must be installed with a IP65/NEMA 4X fitting at the power and ethernet entry points  
<sup>2</sup>The AirMesh Hub holds a rating of IP65 for outdoor when the door is latched and all entry ports (power and Ethernet) are properly sealed. Failure to properly seal entry ports and latch the door will void the IP65 rating.  
<sup>3</sup>Refer to the functionality of your Ephesus fixture for health monitoring capability.

## Example System Topology (Wireless AirMesh Controls)

Example system topology showing the LUMASPORT System in a Wireless AirMesh Control Installation.



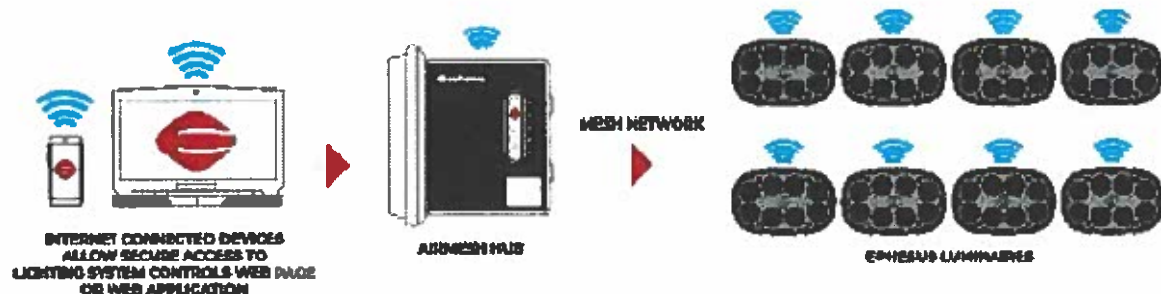

Note: Laptop or mobile device not included. A cellular network connection requires a cellular carrier network plan.



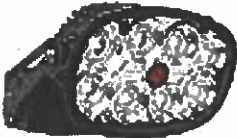
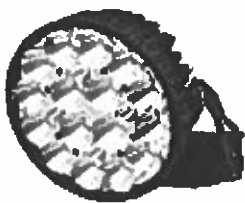

### AirMesh Dynamic Scenes

The AirMesh Hub control system can provide dynamic scenes and effects. You can easily create an unlimited combination of static scenes. For example, create scenes to spotlighting national anthems, player introductions, intermissions, blackout your venue, maintenance and egress lighting scenes.

Ephesus Fixture	Luminaire Type	Static Scenes	Dynamic Scenes
<b>LUMASPORT 8</b> 	White LED	<ul style="list-style-type: none"> <li>• ON/OFF</li> <li>• Dim 10-100%</li> <li>• Blackout</li> <li>• Individual Light Fixture Control</li> <li>• Unlimited Programmable Static Scenes</li> </ul>	<ul style="list-style-type: none"> <li>• Paparazzi [Standard &amp; Fast]</li> <li>• Sparkle [Standard &amp; Fast]</li> <li>• Random</li> </ul>
<b>LUMASPORT 16</b> 	White LED	<ul style="list-style-type: none"> <li>• ON/OFF</li> <li>• Dim 10-100%</li> <li>• Blackout</li> <li>• Individual Light Fixture Control</li> <li>• Unlimited Programmable Static Scenes</li> </ul>	<ul style="list-style-type: none"> <li>• Paparazzi [Standard &amp; Fast]</li> <li>• Sparkle [Standard &amp; Fast]</li> <li>• Random</li> </ul>
<b>PRISM RGBA</b> 	RGBA Color LED	<ul style="list-style-type: none"> <li>• ON/OFF</li> <li>• Dim 0-100%</li> <li>• RGBA Color Mixing</li> <li>• Blackout</li> <li>• Individual Light Fixture Control</li> <li>• Unlimited Programmable Static Scenes</li> </ul>	<ul style="list-style-type: none"> <li>• Paparazzi With Color [Standard &amp; Fast]</li> <li>• Pinwheel With Color</li> <li>• Pinwheel 5 With Color</li> <li>• Sparkle With Color [Standard &amp; Fast]</li> <li>• Random With Color</li> </ul>
<b>ALL FIELD</b> 	White LED	<ul style="list-style-type: none"> <li>• ON/OFF</li> <li>• Dim 0-100%</li> <li>• Blackout</li> <li>• Individual Light Fixture Control</li> <li>• Unlimited Programmable Static Scenes</li> </ul>	<ul style="list-style-type: none"> <li>• Paparazzi Standard &amp; Fast]</li> <li>• Pinwheel</li> <li>• Pinwheel 5</li> <li>• Sparkle [Standard &amp; Fast]</li> <li>• Random</li> </ul>
<b>LUMADAPT 8</b> 	Integrated White / RGBA Color LED	<ul style="list-style-type: none"> <li>• ON/OFF</li> <li>• Dim 0-100%</li> <li>• RGBA Color Mixing</li> <li>• Color Temperature (CCT) Tuning</li> <li>• Beam Angle Tuning</li> <li>• Blackout</li> <li>• Individual Light Fixture Control</li> <li>• Unlimited Programmable Static Scenes</li> </ul>	<p><b>White &amp; RGBA Light</b></p> <ul style="list-style-type: none"> <li>• Paparazzi [Standard &amp; Fast]</li> <li>• Sparkle [Standard &amp; Fast]</li> <li>• Random</li> </ul>



## LUMASPORT 8

Dynamic Scenes

White LED

Lumen(lm) Output:  
55,000 & 90,000



### Paparazzi [Standard & Fast]

Each light illuminates briefly in a random manner that resembles paparazzi flash bulbs.  
When entering this mode, all fixtures will immediately turn OFF. Fast paparazzi fires faster than standard paparazzi.

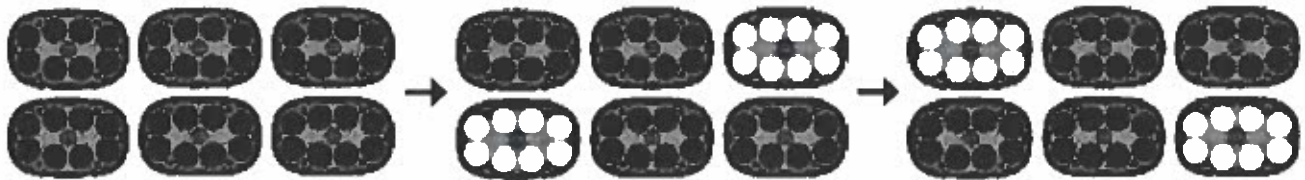

### Sparkle [Standard & Fast]

Each light illuminates briefly in a random manner mimicking a glittery, sparkling appearance.  
When entering this mode, all fixtures will immediately turn ON. Fast Sparkle fires more rapidly than standard sparkle.

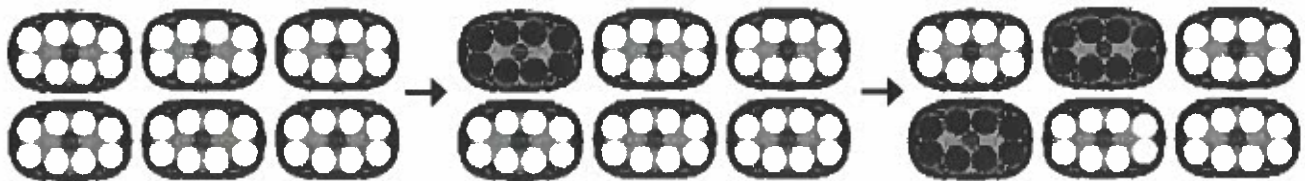

### Random

Lights illuminate throughout the installation in a random manner.  
All fixtures will immediately turn ON to a random dimming level between 0 and 100%. Every 100 milliseconds, each fixture will change to another random dimming level.

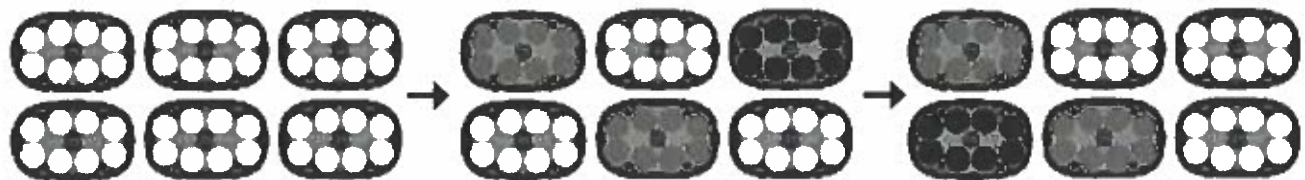

Unless otherwise stated for a particular scene affects independently and the scene will remain in operation until another scene or mode of operation is selected.

<sup>1</sup>For each flash period, a light will have a 10% chance of turning on under Paparazzi, and a 20% chance under Fast Paparazzi. For each flash period, a light will have a 10% chance of turning on under Paparazzi, and a 20% chance under Fast Paparazzi.

<sup>2</sup>For each flash period, a light will have a 10% chance of turning on under Sparkle, and a 20% chance under Fast Sparkle.



# LUMASPORT 16

Dynamic Scenes

White LED  
Lumen(lm) Output: 150,000

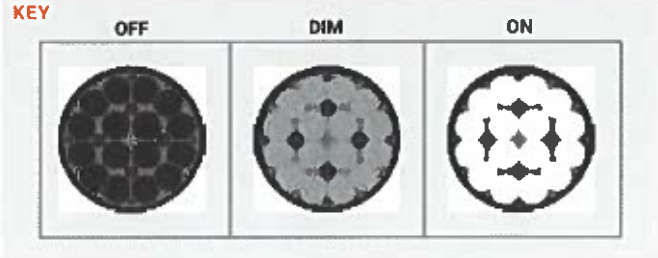

### Paparazzi [Standard & Fast]

Each light illuminates briefly in a random manner that resembles paparazzi flash bulbs.  
When entering this mode, all fixtures will immediately turn OFF. Fast paparazzi fires faster than standard paparazzi.

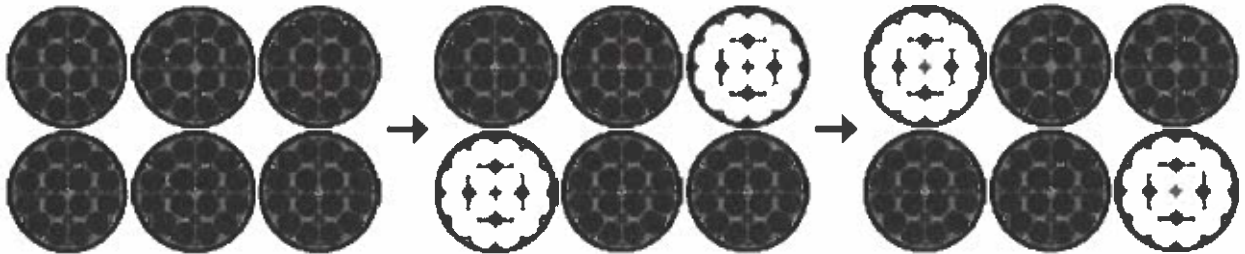

### Sparkle [Standard & Fast]

Each light illuminates briefly in a random manner mimicking a glittery, sparkling appearance.  
When entering this mode, all fixtures will immediately turn ON. Fast Sparkle fires more rapidly than standard sparkle.

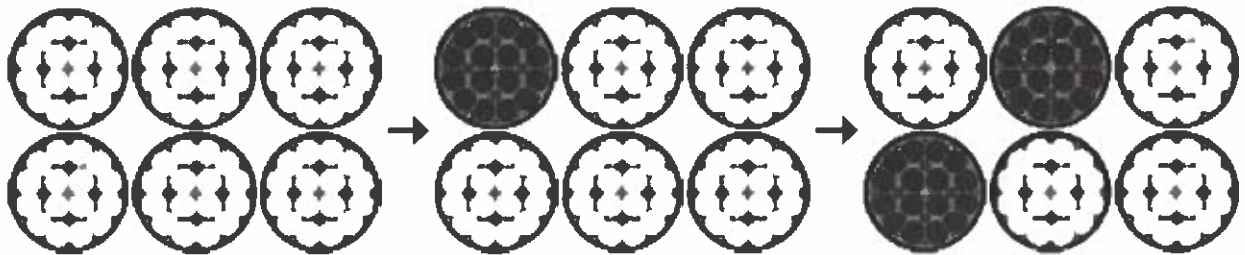

### Random

Lights illuminate throughout the installation in a random manner.  
All fixtures will immediately turn ON to a random dimming level between 0 and 100%. Every 100 milliseconds, each fixture will change to another random dimming level.

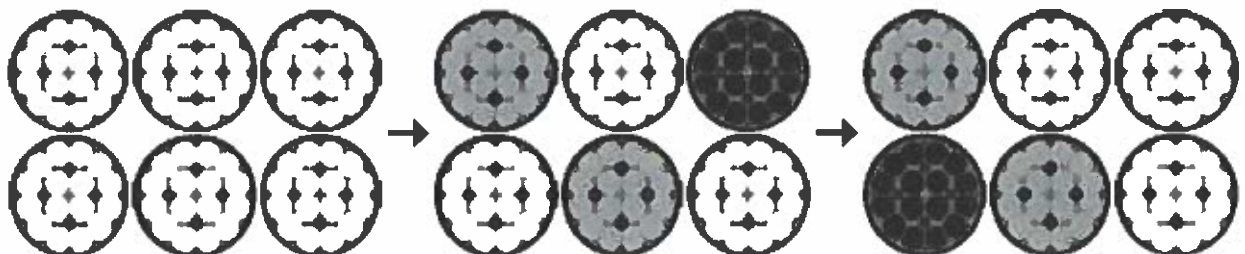

Unless otherwise stated for a particular scene affects independently and the scene will remain in operation until another scene or mode of operation is selected.

\*For each flash period, a light will have a 10% chance of turning on under Paparazzi, and a 20% chance under Fast Paparazzi. For each flash period, a light will have a 10% chance of turning on under Paparazzi, and a 20% chance under Fast Paparazzi.

\*\*For each flash period, a light will have a 10% chance of turning on under Sparkle, and a 20% chance under Fast Sparkle



## PRISM RGBA

### Dynamic Scenes

### RGBA Color LED

Lumen(lm) Output:

R>10,840 | G>12,900

B>2,450 | A>10,800



#### Paparazzi [Standard & Fast]

Each light illuminates briefly in a random manner that resembles paparazzi flash bulbs.

When entering this mode, all fixtures will immediately turn OFF. Fast paparazzi fires faster than standard paparazzi.

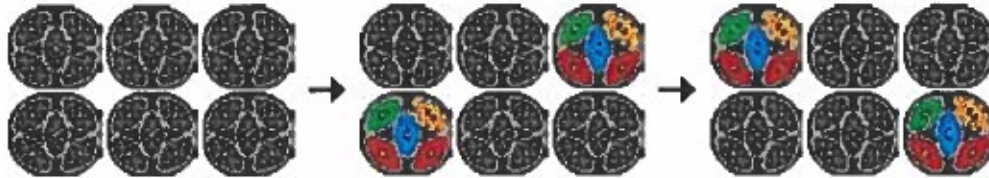

#### Pinwheel

The outer LED modules on each fixture illuminate individually and rapidly in a rotating manner.

When entering this mode, the center LED module on each fixture will turn OFF. All but one of the four outer LED modules will turn off. Every 100 milliseconds, the next outer LED module (clockwise) will turn on to 100% and the previous LED module will turn off.

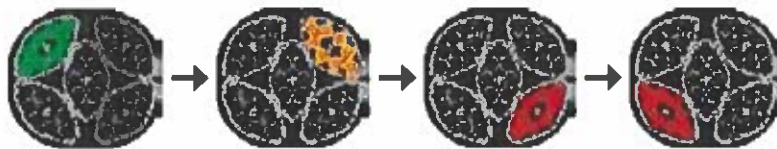

#### Pinwheel 5

All LED modules on each fixture illuminate individually and rapidly in a rotating manner.

When entering this mode, all but one of the outer LED modules will turn off. Every 100 milliseconds, the next LED module (clockwise) ending with the center LED module will turn on to 100% and the previous LED module will turn off.



#### Sparkle [Standard & Fast]

Each light illuminates briefly in a random manner mimicking a glittery, sparkling appearance.

When entering this mode, all fixtures will immediately turn ON. Fast Sparkle fires more rapidly than standard sparkle.



#### Random

Lights illuminate throughout the installation in a random manner.

All fixtures will immediately turn ON to a random dimming level between 0 and 100%. Every 100 milliseconds, each fixture will change to another random dimming level.

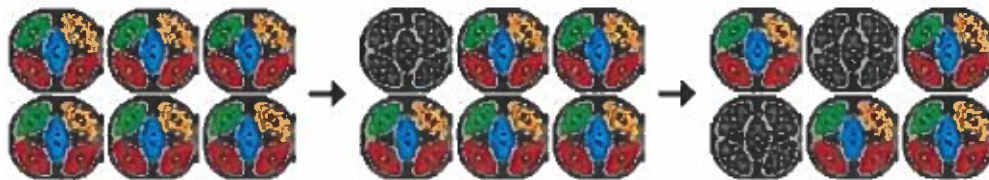

Unless otherwise stated for a particular scene affects independently and the scene will remain in operation until another scene or mode of operation is selected.

\*For each flash period, a light will have a 10% chance of turning on under Paparazzi, and a 20% chance under Fast Paparazzi. For each flash period, a light will have a 10% chance of turning on under Paparazzi, and a 20% chance under Fast Paparazzi.

\*For each flash period, a light will have a 10% chance of turning on under Sparkle, and a 20% chance under Fast Sparkle.

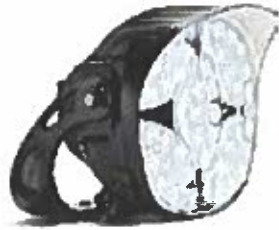

## ALL FIELD

### Dynamic Scenes

White LED

Lumen(lm) Output:  
 >48,000 | >64,000 | >85,000

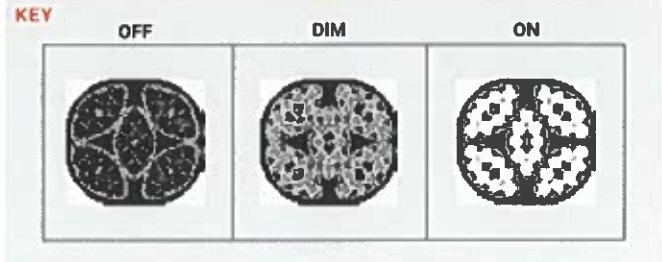

#### Paparazzi [Standard & Fast]

Each light illuminates briefly in a random manner that resembles paparazzi flash bulbs. When entering this mode, all fixtures will immediately turn OFF. Fast paparazzi fires faster than standard paparazzi.

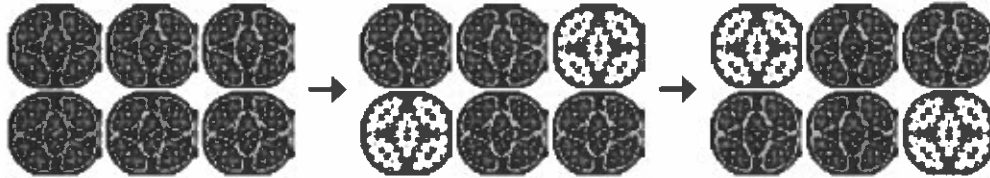

#### Pinwheel

The outer LED modules on each fixture illuminate individually and rapidly in a rotating manner. When entering this mode, the center LED module on each fixture will turn OFF. All but one of the four outer LED modules will turn off. Every 100 milliseconds, the next LED module (clockwise) will turn on to 100% and the previous LED module will turn off.

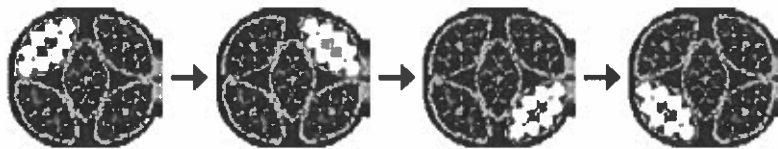

#### Pinwheel 5

All LED modules on each fixture illuminate individually and rapidly in a rotating manner. When entering this mode, all but one of the outer LED modules will turn off. Every 100 milliseconds, the next LED module (clockwise) ending with the center LED module will turn on to 100% and the previous LED module will turn off.



#### Sparkle [Standard & Fast]

Each light illuminates briefly in a random manner mimicking a glittery, sparkling appearance. When entering this mode, all fixtures will immediately turn ON. Fast Sparkle fires more rapidly than standard sparkle.

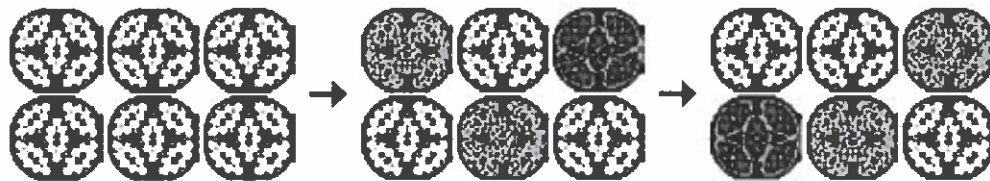

#### Random

Lights illuminate throughout the installation in a random manner. All fixtures will immediately turn ON to a random dimming level between 0 and 100%. Every 100 milliseconds, each fixture will change to another random dimming level.

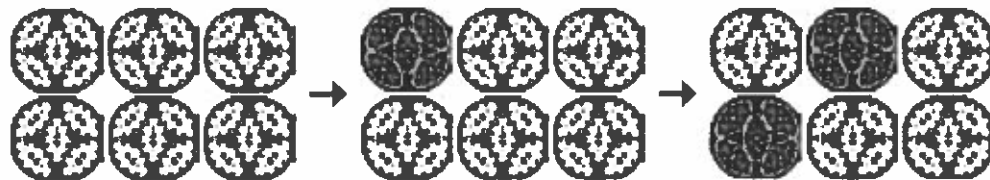

Unless otherwise stated for a particular scene affects independently and the scene will remain in operation until another scene or mode of operation is selected.  
 \*For each flash period, a light will have a 10% chance of turning on under Paparazzi, and a 20% chance under Fast Paparazzi. For each flash period, a light will have a 10% chance of turning on under Paparazzi, and a 20% chance under Fast Paparazzi.  
 \*For each flash period, a light will have a 10% chance of turning on under Sparkle, and a 20% chance under Fast Sparkle.



# LUMADAPT 8

Dynamic Scenes

Integrated White & RGBA Color LED

Lumen(lm) Output: up to 50,000



### Paparazzi [Standard & Fast]<sup>1</sup> with White and RGBA Color

Each light illuminates briefly in a random manner that resembles paparazzi flash bulbs.

When entering this mode, all fixtures will immediately turn OFF. Fast paparazzi fires faster than standard paparazzi

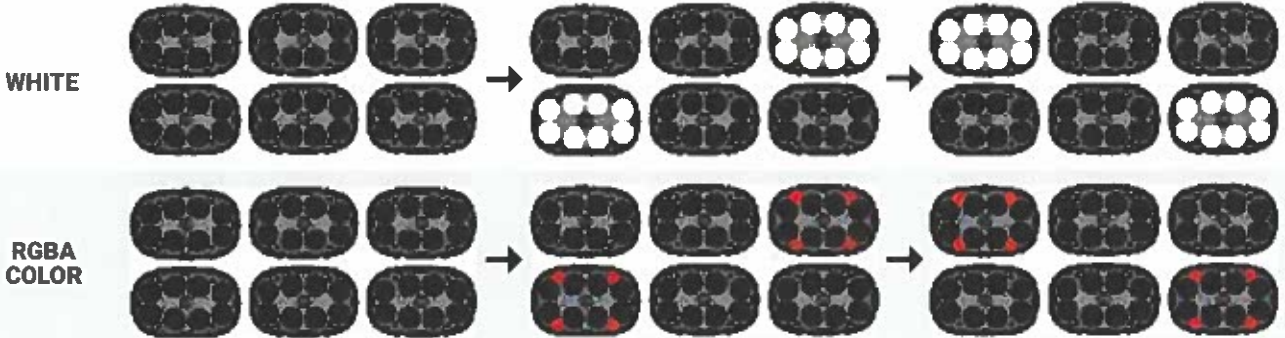

### Sparkle [Standard & Fast]<sup>2</sup> with White and RGBA Color

Each light illuminates briefly in a random manner mimicking a glittery, sparkling appearance.

When entering this mode, all fixtures will immediately turn ON. Fast Sparkle fires more rapidly than standard sparkle

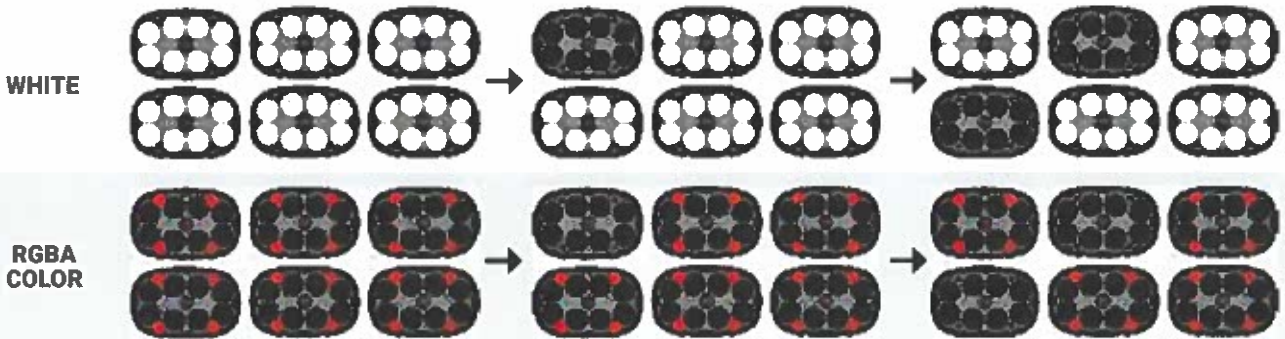

### Random with White and RGBA Color

Lights illuminate throughout the installation in a random manner.

All fixtures will immediately turn ON to a random dimming level between 0 and 100%. Every 100 milliseconds, each fixture will change to another random dimming level.

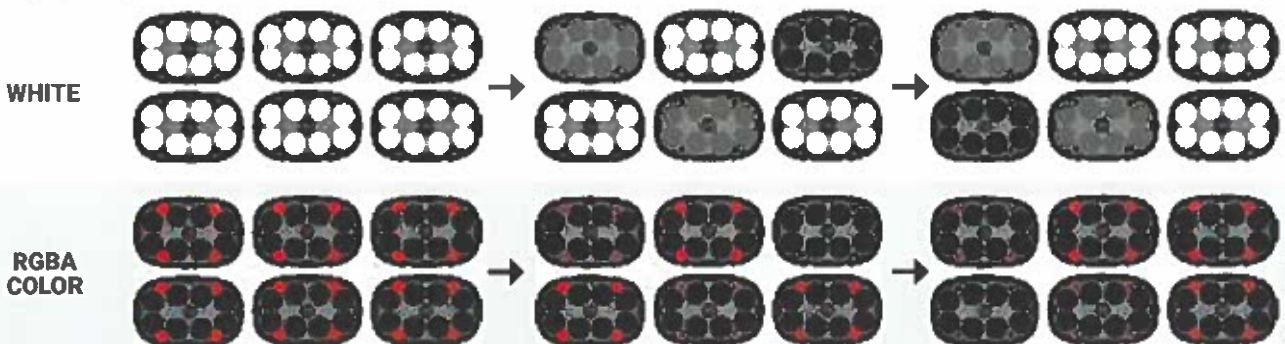

Unless otherwise stated for a particular scene affects independently and the scene will remain in operation until another scene or mode of operation is selected.

<sup>1</sup>For each flash period, a light will have a 10% chance of turning on under Paparazzi, and a 20% chance under Fast Paparazzi. For each flash period, a light will have a 10% chance of turning on under Paparazzi, and a 20% chance under Fast Paparazzi.

<sup>2</sup>For each flash period, a light will have a 10% chance of turning on under Sparkle, and a 20% chance under Fast Sparkle.

**Cooper Lighting #071619-CPL**

Pricing for contract #071619-CPL offers Sourcewell participating agencies 5% off MSRP